

URBAN POOL XL 6.50 m x 3.50 m with integrated automatic cover

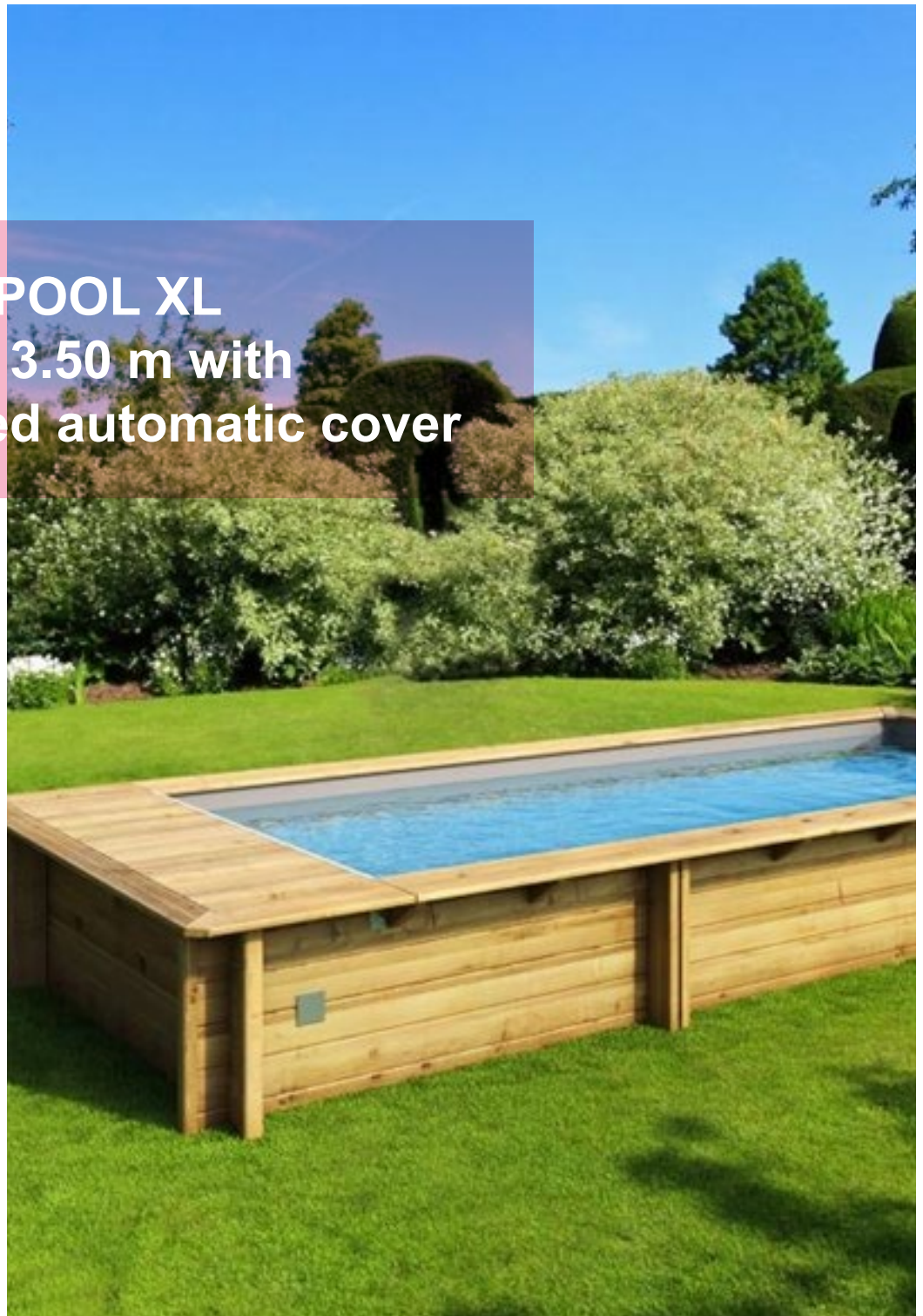

INSTALLATION AND OPERATING INTRUCTIONS

to be read carefully and kept for future reference

1. PRESENTATION	6
2. FOREWORD	6
2.1 Storage	6
2.2 An above-ground kit	6
2.3 Safety	6
2.4 Assembly	7
2.4.1 Assembly steps	7
2.4.2 Tools	7
2.4.3 Assembly time	7
3. NOMENCLATURE	8
3.1 Wood and coping pack	8
3.2 Accessories pack	8
3.2.1 Screws for the pool structure	8
3.2.2 Pool structure metalwork	10
3.2.3 Filtration system	10
3.2.4 Accessories	11
3.3 Automatic cover pack	11
3.3.1 Mechanical assembly and automatic cover slat apron	11
3.3.2 Ladder rails	11
4. WOOD, A NATURAL MATERIAL	12
4.1 Colour variations	12
4.2 Resin beads	12
4.3 Salt stains	12
4.4 Greying	12
4.5 Splitting and cracking	13
4.6 Knots	13
4.7 Surface mould	13
4.8 Joined wood	13
4.9 Curved wood	13
5. EARTHWORKS	14
5.1 Introduction	14
5.2 Creating the excavation	14
5.2.1 Material quantities	14
5.2.2 Excavation	14
5.2.3 Drainage	14
5.2.4 Stone bedding	16
5.3 Installing the supporting braces	16
5.4 Pouring the concrete slab	19
5.4.1 Rebar	19
5.4.2 Slab dimensions	19
6. ASSEMBLING THE WOODEN STRUCTURE	21
6.1 Introduction	21
6.2 Application of the bituminous strips	23
6.3 Assembling the slats	23
6.4 Mounting the finishing trim on the supporting braces	25
6.5 Mounting the coping corbels	25
6.6 Assembling the wooden access ladder	26
6.7 Mounting the metal fittings	27
6.8 End grain sealer	27
6.9 Finishing trim	27

7. INSTALLATION OF THE FILTRATION SYSTEM	28
7.1 Filtration group components	29
7.1.1 Rigid module	29
7.1.2 Return fitting.....	29
7.1.3 Skimmer.....	29
7.2 Skimmer.....	30
7.3 Return fitting body.....	31
7.4 Filtration pipework.....	31
7.4.1 Installation of the rigid descending modules	32
8. ASSEMBLING AND COMMISSIONING THE FILTER GROUP.....	33
8.1 Filtration components components and specifications	34
8.2 Assembling the filter	35
8.3 Instructions for fitting the filter lid	38
8.4 Pump filter & collector module.....	39
8.5 Connecting the pipes	39
9. PARTS FOR THE AUTOMATIC COVER.....	40
9.1 Throughwall flange	40
9.2 Bearing mounting unit.....	41
10. IN-POOL LADDER	42
10.1 Assembling the in-pool ladder	42
10.2 Drilling holes to mount the ladder.....	42
11. FITTING THE WATERPROOFING MEMBRANE	43
11.1 Installing the liner locking track.....	43
11.2 Drilling for the beam mounting unit.....	43
11.3 Applying self-adhesive gaskets	44
11.4 Fitting the underlay.....	44
11.5 Fitting the liner.....	44
11.6 Underwater light cable ties	45
11.7 Filling the pool with water.....	45
11.8 Installing flanges on plastic pool fittings	45
11.8.1 Return fitting flange.....	46
11.8.2 Throughwall fitting flange.....	46
11.8.3 Bearing mounting unit flange	47
11.8.4 Skimmer flange.....	47
11.9 Installation of the ladder rails.....	47
12. ASSEMBLY OF THE AUTOMATIC COVER	48
12.1 Assembly of the automatic cover axle	48
12.1.1 Installation of the stainless steel shaft	48
12.1.2 Fitting the axle into the bearing mounting unit.....	48
12.1.3 Fitting the automatic cover shaft into the axle.....	48
12.2 Beam and beam flanges.....	49
12.3 Installing the pit wall and the underwater light.....	50
12.4 Automatic cover apron and safety fasteners	50
12.4.1 Advice prior to installation	50
12.4.2 Assembling the slat cover.....	50
12.4.3 Installing the cover apron safety fastener	51
12.4.4 Securing and releasing the slat cover	52
12.5 Water level in the pool for correct operation of the cover	53

13. INSTALLATION OF THE COPING AND FINISHING ELEMENTS	54
13.1 Coping	54
13.2 Assembling and installing the duckboarding	55
13.3 Ladder hand rail	56
13.4 Wiring	56
13.5 Automatic cover motor	56
13.5.1 Safety advice concerning the motor	57
13.5.2 Assembly of the automatic cover motor	57
13.6 Electrical panel: mounting and wiring	57
13.6.1 Mounting the electrical panel on the wall	58
13.6.2 Electrical panel power supply	58
13.6.3 Connecting the filtration pump	58
13.6.4 Connecting the underwater light	58
13.6.5 Connecting the motor	58
13.6.6 Connecting the end of travel sensors	59
13.6.7 Connecting the key switch	59
13.7 Adjusting the ends of travel	60
14. COVER PIT FOR URBAN POOLS	61
14.1 Nomenclature	62
14.1.1 Hardware	62
14.1.2 Wooden elements	62
14.2 Cover pit exploded view	63
14.3 Assembly	63
14.3.1 Assembling the walls	64
14.3.2 Mounting the finishing trim on the ends of the walls	64
14.3.3 Swapping out the pool corner cleat	65
14.3.4 Fastening the cover pit to the pool	65
14.3.5 Fastening the hinges to the cover pit	65
14.3.6 Duckboarding assembly	65
14.3.7 Positioning the coping on the cover pit	66
14.3.8 Assembling the lock	66
15. SAFETY	67
15.1 Electrical supply and filtration pump safety	67
15.2 Safety of all users	67
15.3 Safety of children	67
15.4 Safety cover	68
16. WATER TREATMENT	69
16.1 Water filtration	69
16.1.1 Using the filter mutli-port valve	69
16.1.2 Commissioning the filter	69
16.1.3 Cleaning the pre-filter and the filter	69
16.1.4 Length of the filtration cycle	70
16.1.5 Setting the filtration timer	70
16.2 Maintaining pool water quality	71
17. MAINTENANCE OF YOUR URBAN POOL	71
17.1 Maintenance of the pool structure	71
17.2 Maintenance of the filtration pump	72
17.3 Maintenance of the cover	72
17.4 Winterizing the pool	72

18. GUARANTEE CONDITIONS.....	73
18.1 Guarantee covering the wooden components.....	73
18.2 Guarantee covering accessories	73
18.2.1 Liner guarantees	73
18.2.2 Guarantee covering the sand filtration pump.....	74
18.2.3 Guarantee covering ABS fittings (skimmer, return fitting)	74
18.3 Guarantee covering the automatic cover	75
18.3.1 Guarantee covering the automatic cover mechanical assembly	75
18.3.2 Guarantee covering the PVC slats of the cover apron	76
19. ENVIRONMENTAL PROTECTION AND DISPOSAL.....	77

1. PRESENTATION

For your comfort and safety, URBAN pools are fitted with a submerged automatic cover that complies with the French pool safety standard (NF P90 308), an attribute usually associated with large, top of the range pools. Housed under the coping the submerged cover keeps the pool water warm and provides discreet protection for your pool.

2. FOREWORD

Once you have built your pool, keep the documentation (installation instructions, invoice, etc). You will need these for any future exchanges with our various services.

Great care has gone into the manufacture of your pool, however, some precautions are necessary for its correct assembly and use. We strongly recommend that you read the installation instructions carefully before beginning assembly of the pool, and that you keep them for future reference concerning the use and maintenance of the pool.

In the event of any claim, you will need to quote the pool's tracking number that you will find at the end of this document.

2.1 Storage

If you do not intend to assemble your pool immediately do not unpack the components, store the boxes in a suitable, well ventilated, cool area protected from the sun and bad weather. The purpose is to avoid deformation of the wooden elements that would make assembly more difficult.

Deformation of the wood could only be caused by storing the wood other than as recommended. If you had to unpack your pool, you must repack and restrap the pallet of wooden elements.

Once the wooden elements are unpacked, proceed with assembly within the next 24 to 48 hours. While storing the boxes, we recommend that you remove the film and insert wooden wedges between each layer of wood to facilitate the circulation of air.

2.2 An above-ground kit

The kit delivered is for an above-ground installation. If the pool is to be installed in-ground (or partially in-ground) some extra work and materials will be required:

- the URBAN pool wooden plant housing ;
- the necessary excavation work ;
- creation of a drain and a relief well adapted to the terrain around the periphery of the concrete slab ;
- a foundation membrane to cover the in-ground sections of wall ;
- backfill behind the walls with 10/20 rolled gravel.

The necessary supplies are not included in the kit.

2.3 Safety

Your electrical installation must comply with the standard in effect in the country of installation (C15-100 in France). Notably, the electrical supply of the pump should be protected by a 30mA residual current device. Do not hesitate to have this work carried out by a professional to ensure the compliance of your installation.

The kit provided will allow installation of the filtration system 3.5 m from the pool in accordance with the French safety standard NF C15-100.

Subject to the condition that the cover is mounted according to the installation instructions provided in this document, the safety cover equipping your Urban pool will secure access to the pool in accordance with the French safety standard NF P90 308.

Children should only use the pool under the supervision of an adult. This pool is intended for private use only. Installation of the pool beneath trees is not advised, installation beneath electrical wires is strictly prohibited.

2.4 Assembly

2.4.1 Assembly steps

- excavate ;
- assemble the supporting braces ;
- pour the concrete slab ;
- assemble the wooden structure ;
- install the filtration system and pool fittings ;
- assemble the vertical section of the ladder ;
- fit the waterproofing membrane ;
- assemble the automatic cover ;
- install the coping and finishing trim ;
- wiring.

2.4.2 Tools

Not including the materials required for excavation and pouring the concrete slab, we recommend that you have the following equipment on hand:

- measuring tools: decameter, rope, big spirit level ;
- mallet ;
- drill and drill bits, flat head screw driver, cross head screw driver, drill bit diameter 10 mm ;
- cutting tools: Stanley knife, metal saw, hole saw diameter 60 mm ;
- tube or socket wrench (13 and 17mm), set of Allen keys ;
- finishing tools: sand paper, lime fine ;
- tools for glueing pipework: medium sand paper, PVC stripper.

2.4.3 Assembly time

Excavation and earthworks: **2 DAYS DEPENDING ON THE MATERIALS USED**

Supporting braces: **½ DAY (WITH 2 PEOPLE)**

Pouring the slab: **½ DAY (WITH TWO PEOPLE) DEPENDING ON THE MATERIALS USED**

Wooden structure and cover: **2 DAYS (WITH TWO PEOPLE - THE TIME INDICATED DOES NOT INCLUDE THE CONCRETE CURING TIME)**

Curing of the concrete slab: **21 DAYS (3 WEEKS)**

CAUTION

Once the structure has been assembled, the liner must be fitted and the pool must be filled with water within at most 5 days. Past this time limit, the structure will need to be carefully inspected to ensure the absence of any deformation (movement of the slats, shrinkage, etc.) that could impact the structural integrity of the work. In the event that gaps appear between the slats, reengage the slats properly before fitting the liner.

3. NOMENCLATURE

3.1 Wood and coping pack

	DESCRIPTION	FIGURE	REF	DIMENSIONS (MM)	TYPE
4	Wall slat	<i>Figure 8</i>	n°1	1700 × 78 × 45	Male
60	Wall slat	<i>Figure 8</i>	n°2	1700 × 145 × 45	Male/female
2	Wall slat	<i>Figure 8</i>	n°3	1700 × 145 × 45	Male/female, machined to receive the return fitting
2	Wall slat	<i>Figure 8</i>	n°4	1700 × 145 × 45	Male/female, machined to receive the throughwall flange
2	Wall slat	<i>Figure 8</i>	n°5	1700 × 145 × 45	Male/female, machined to receive the throughwall flange
2	Wall slat	<i>Figure 8</i>	n°16	1700 × 145 × 45	Male/female, machined to receive the skimmer
1	Wall slat	<i>Figure 8</i>	n°6	523 × 137 × 45	Left female for skimmer
1	Wall slat	<i>Figure 8</i>	n°8	691 × 137 × 45	Left female for skimmer
1	Wall slat	<i>Figure 8</i>	n°7	523 × 137 × 45	Right female for skimmer
1	Wall slat	<i>Figure 8</i>	n°9	691 × 137 × 45	Right female for skimmer
36	Wall slat	<i>Figure 8</i>	n°10	1570 × 145 × 45	Male/female
1	Wall slat	<i>Figure 8</i>	n°11	1700 × 137 × 45	Female left
1	Wall slat	<i>Figure 8</i>	n°12	1700 × 137 × 45	Female right
4	Wall slat	<i>Figure 8</i>	n°13	1570 × 70 × 45	Female
2	Wall slat	<i>Figure 8</i>	n°14	1700 × 70 × 45	Female left
2	Wall slat	<i>Figure 8</i>	n°15	1700 × 70 × 45	Female right
16	Trim	<i>Figure 14</i>	-	1290 × 137 × 45	For supporting braces
14	Coping corbel	<i>Figure 15</i>	-	180 × 150 × 45	For coping
1	Ladder rail	<i>Figure 18</i>	-	1330 × 95 × 35	For steps
4	Ladder tread	<i>Figure 18</i>	-	600 × 145 × 27	For steps
8	Coping	<i>Figure 22</i>	-	1295 × 70 × 45	To finish the corners
2	Coping	<i>Figure 51</i>	n°1	1570 × 145 × 28	Interior left
2	Coping	<i>Figure 51</i>	n°2	1570 × 145 × 28	Interior right
4	Coping	<i>Figure 51</i>	n°3	1716 × 145 × 28	Exterior left
4	Coping	<i>Figure 51</i>	n°4	1716 × 145 × 28	Exterior right
1	Coping	<i>Figure 51</i>	n°5	1621 × 145 × 28	Interior left
1	Coping	<i>Figure 51</i>	n°6	1621 × 145 × 28	Interior right
8	Coping	<i>Figure 51</i>	n°7	1500 × 145 × 28	Interior and exterior
2	Mitered cleat	<i>Figure 51</i>	n°8	206 × 70 × 28	Corner
2	Mitered cleat	<i>Figure 51</i>	n°9	412 × 70 × 28	Corner
10	Straight cleat	<i>Figure 52</i>	-	585 × 70 × 28	For duckboarding
20	Duckboarding	<i>Figure 52</i>	-	600 × 145 × 28	-
2	Wall slat		-	≈ 290 × 145 × 45	For martyr block

3.2 Accessories pack

3.2.1 Screws for the pool structure

QTY	DESCRIPTION	KIT	PURPOSE
3	Torx safety screw 6 × 30, A2 SS	Y	Fasten the elastic strap underneath the duckboarding
4	Hex screw M8 × 120, A2 SS, DIN 931	Y	Fasten the beam and counter plate to the polyamide blocks from outside the pool
4	Screw, M8 × 70 DIN 603 A4 (round head, square neck)	Y	Fasten the beam and counter plate from inside the pool
4	Countersunk screws, 4.2 × 19, A4 SS, DIN 7982	Y	Fasten the polyamide blocks to the pit wall flanges

7	Stove screws, M8 × 16, A4 SS torx	Y	Fasten the elastic strap at the bottom of the pit wall modules (x 3) Fasten the pit wall to the beam mounting plate (× 4)
8	Hex screws, M8 × 20, A4 SS,	Y	Assembly of the pit wall modules
23	Nut M8, A4 SS	Y	Fasten the pit wall brackets to the beam mounting plates (4 nuts & 4 washers) Fasten the beam and counterplate from inside the pool (4 nuts & 4 washers) Assembly of the pit wall modules (16 nuts & 16 washers) Fasten straps to the pit wall (3 nuts & 3 washers) Fasten the pit wall to the beam mounting plate (4 nuts & 8 washers)
35	Washer M8, A4 SS	Y	Fasten the pit wall brackets to the beam mounting plates (4 nuts & 4 washers) Fasten the beam and counterplate from inside the pool (4 nuts & 4 washers) Assembly of the pit wall modules (16 nuts & 16 washers) Fasten straps to the pit wall (3 nuts & 3 washers) Fasten the pit wall to the beam mounting plate (4 nuts & 8 washers)
56	Nut, M10, zinc plated steel	A	Fasten the 3 jacks to each of the four supporting braces
8	Nut, M8, A4 SS, DIN 934	B	Fasten the ladder hand rail to the coping
8	Washer M8 SS A4	B	
8	Mushroom head screw, M8x50, A2 SS	B	
160	Countersunk screw, 5 × 40 A4 SS, torx, threaded over 25 mm	C	Lock the slats together at the supporting braces
80	Torx safety screw 6 × 30, A2 SS	D	Fasten the wall slats to the supporting braces from outside the pool
416	Torx safety screw 6 × 20, A2 SS	G	Fasten the coping modules to the coping corbels
100	Countersunk screw, 4×35 A4 SS, torx, threaded over 20 mm	H	Mount the Hung track under the coping
24	Domed head nail, 2.8 × 60, A2 SS	I	Fasten the finishing trim to the walls (3 nails per profile)
16	Countersunk screw 5 × 60 zinc plated torx threaded over 35 mm	K	Assembly of the wooden steps: fasten the 4 treads to the 2 rails
4	Countersunk screw 4 × 25 zinc plated torx	K	Mount the warning panel
28	Countersunk screw 5 × 100, A4 SS, torx, threaded over 60 mm	L	Mount the wooden coping corbels on the walls (2 × 14 consoles)
48	Countersunk screw 5 × 80, A4 SS, torx, threaded over 50 mm	L	Fasten the trim over the supporting braces

56	Countersunk screw 5 × 40, A4 SS, torx, threaded over 25 mm	M	Fasten the metallic plates to the wooden coping corbels (4 x 14)
16	H head screw M8x25 zinc plated steel	M	Mount the skimmer bracket
16	M8 nut zinc plated steel	X	Mount the upper connecting plates
16	Countersunk screw 5.5x25 SS A4 torx	X	
80	Countersunk screw 5 × 40 SS A4 torx threaded over 25 mm	Z	Assembly of the duckboarding (4 x 13 duckboarding)
1	Torx bits	J	T20 ; T25 ; T30
1	Wood drill bits 4 × 75 mm	J	Pre-drill the liner locking rail (hung)

3.2.2 Pool structure metalwork

QTY		DESCRIPTION
1	Steel mounting elements kit:	Coping module fittings (× 12 right, × 12 left)
		Corner coping module fittings (× 4)
		Jacks for the supporting braces (× 12 back, × 8 front)
1	Metalwork kit:	Beam mounting unit counter plate(× 2)
		Hand rail bracket (× 1 right, × 1 left)
		Skimmer blocking bracket (× 2)
		Pit wall bracket (× 2)
		Pit wall flange (× 2)
14		Metallic plates to fasten the coping modules (only 14 of the 17 plates will be used)
8		Steel support braces

3.2.3 Filtration system

QTY		DESCRIPTION
1	Filtration pump and unions	2 skimmer suction modules
		Suction manifold 2 inlets
		Filtration pump P-AP 8m3/h, 1ph
		Pump base
		Sand filter P-FI 500
		Filter base
		Two 25kg of sand
		Isolation module for P-FI filter
		Y module for return fittings
		2 return fitting modules
		15 m of grey pipes D45
1	Pack of pool fittings	2 complete skimmers (body, flange and trim, seals, set of screws, weir)
		2 complete return fittings (body, flange, eyeball and trim, seals, set of screws)

3.2.4 Accessories

QTY	DESCRIPTION
1	Installation instructions
1	Warning panel to mount on the pool wall
1	Bitumous strips to provide insulation between the pool walls and the concrete slab
2	Roll of black plasticised PVC to protect the liner against screw heads
1	Underlay
1	Grey liner
16	1.18 m length of PVC liner locking track
2	SS hand rails

3.3 Automatic cover pack

3.3.1 Mechanical assembly and automatic cover slat apron

QTY	DESCRIPTION
1	Anodised aluminium axle, Ø150, length 2790 mm, with two stands, a bearing and three supports to attach the slat apron
1	SS motor shaft, 309 mm, for the throughwall flange with plastic locking pin and screw
1	Throughwall flange (body, gaskets, flange and screws)
1	Bearing (body, gaskets, flange and screws)
1	Automatic cover apron (49 slats) fitted with three connection straps on the axle side and two safety fastening straps
2	Automatic cover safety fastener
1	Electrical panel with control pad for the automatic cover, key switch, filtration timer and water slinger (o-ring) for the SS motor shaft, 309 mm, inserted in the throughwall flange
1	Urban pool reduction geared motor with pins (pin for SS shaft and U shaped pin)
1	Lacquered aluminium beam 60 x 87 x 1988 mm with gaskets (4 washers and 4 plates) and 2 polyamide blocks
3	Pit wall module
1	LED underwater light
3	Black elastic strap to hold the automatic cover apron

3.3.2 Ladder rails

QTY	DESCRIPTION
2	Aluminium rails ,Ø40, and ball joints
3	ABS treads with aluminium screws
2	Support, shell and adhesive gaskets with SS screws
2	Bumpers to protect the liner

4. WOOD, A NATURAL MATERIAL

Being a natural material, wood will have some imperfections. These are normal and have no impact on the service life of the product.

A certain number are superficial and do not fall within the scope of the guarantees.

4.1 Colour variations

Colour variations are common to every species of wood. Treatment brings them out because the depth of penetration of the product depends on the wood density and grain. Weathering of wood outdoors will significantly attenuate these colour variations.



4.2 Resin beads

When resinous wood species are autoclaved, the alternating pressure and vacuum can cause sticky residue to rise to the surface. To remove it, scrape it carefully with an appropriate tool, being careful not to touch the wood. Turpentine spirits could also be effective, but could stain the wood if too much is applied.



4.3 Salt stains

Small green stains are frequently found on the surface of autoclaved wood. These can be removed with light sanding. If left untreated, this colour will disappear over time.



4.4 Greying

Wood exposed to the sun and the moon is susceptible to greying. Some of the wood could already be greyed due to the storage conditions of the various elements of the structure.

This is a natural phenomenon that has no impact on the structural integrity of the product. The colour of the whole structure will even out after a few months of exposure..



4.5 Splitting and cracking

Wood expands and contracts when exposed to variations in humidity and temperature. As it dries, wood contracts unevenly resulting in the appearance of cracks. While these can seem to be cause for concern, they have no impact on the mechanical properties of the product and therefore do not fall within the scope of the guarantee.



4.6 Knots

Knots mark the places where branches were attached. The quantity and size depends on the species of wood and the sorting process. For outdoor installations, small adherent knots are acceptable.



4.7 Surface mould

Mould, caused by microscopic fungi, can grow on wood, particularly on resinous species, on which the growth can appear as “blueing”. It is a surface phenomenon, exacerbated by heat, humidity and inadequate aeration and is characterised by stains ranging from light to dark blue. They can be removed by wiping the surface.

Remember that class IV treated wood is protected against attack by fungi that could destroy the physical and mechanical properties of the wood.



4.8 Joined wood

To ensure the highest quality in the selection of our wood, it is sorted meticulously before planing. Sections that features defects on both sides are removed and the wood is then joined together (see image).

This in no way penalises the mechanical properties of the wood.

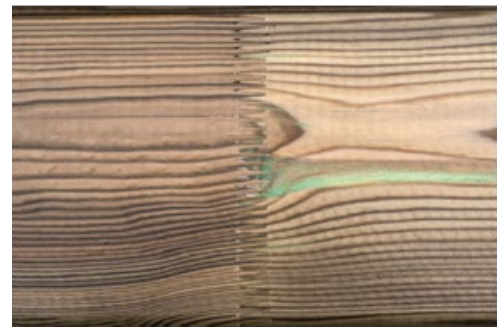

4.9 Curved wood

Due to the constant pressure exerted by the water, the walls of the pool may curve slightly over time.

This phenomenon, attributable to the natural elasticity of wood, will stabilise of its own accord and in no way would lead to failure of the wooden slats.

It is not a defect, and would not constitute grounds for a guarantee claim.

5. EARTHWORKS

5.1 Introduction

After determining the ideal position for your pool (preferably, orient the pool so that skimmers face into dominant winds), start with the excavation required to accommodate the concrete slab that will seal in the support braces and form the base of your pool. Seek the assistance of a professional if required.

Never backfill under the pool to achieve a level surface, the layer of stone bedding and the slab must be seated on stable ground.

In this section on earthworks, information provided takes into account the plant housing and the drainage system required for an in-ground or partially in-ground installation. For an above-ground installation, the plant housing and drainage system are not required. The excavation and the slab will be rectangles, 7190 mm long and 4190 mm wide.

5.2 Creating the excavation

5.2.1 Material quantities

The quantities of materials required are shown in the table below



Estimated volume of stone bedding	3.7 m ³	20/40 gravel
Geotextile surface area (pool floor)	31.6 m ²	nonwoven felt
Polyane surface area	31.6 m ²	polyethylene sheet
Theoretical length of the Ø80 mm drain	31.6 m	PVC
Rebar	34 m	ST25C rebar
Slab, 15 cm thick	5.2 m ³	C25/30 concrete
Protective membrane for in-ground walls (rolls 1.5 m high)	33 ml	polyethylene
Backfill	20 m ³	10/20 rolled gravel

5.2.2 Excavation

Dig out an area, the length and the width of which should correspond to the length and width of the inner walls of the pool increased by 0.55 m around the entire periphery of the pool, that is, 7.1 x 4.1 m for a pool without a plant housing.

For an above-ground installation, so that the slab is flush with the ground, excavate to a depth of 0.26 m. For partially in-ground installations, the depth of the hole is determined by the installer. For example, to sink the pool 1 m into the ground (leaving 33 cm above ground), the hole should be 1.26 cm deep.

To install the pool fully in-ground (bottom of the coping flush with the ground), the hole should be 1.56 m deep.

-  Take care, this measurement may be greater if the moisture content of the wood is high when the pool is installed (wood stored in a humid or poorly ventilated area).
-  The structural dimensions and measurements listed have a tolerance of +/- 3% (European standard EN 16582-1). The AFNOR AC P90-321 agreement allows the following deviation in terms of depth: For a depth greater than 1.25 m and less than or equal to 1.65 m: +/- 5 cm.

5.2.3 Drainage

In the case of an in-ground installation, create a drain around the entire outer periphery of the pool. The drain, which should have a diameter of 80 cm, should be connected to a relief well located in one of the corners on the outside edge of the excavation. The relief well should be 0.5 m deeper than the floor of the excavation and should have a diameter of at least 0.3 m to accommodate a lift pump.

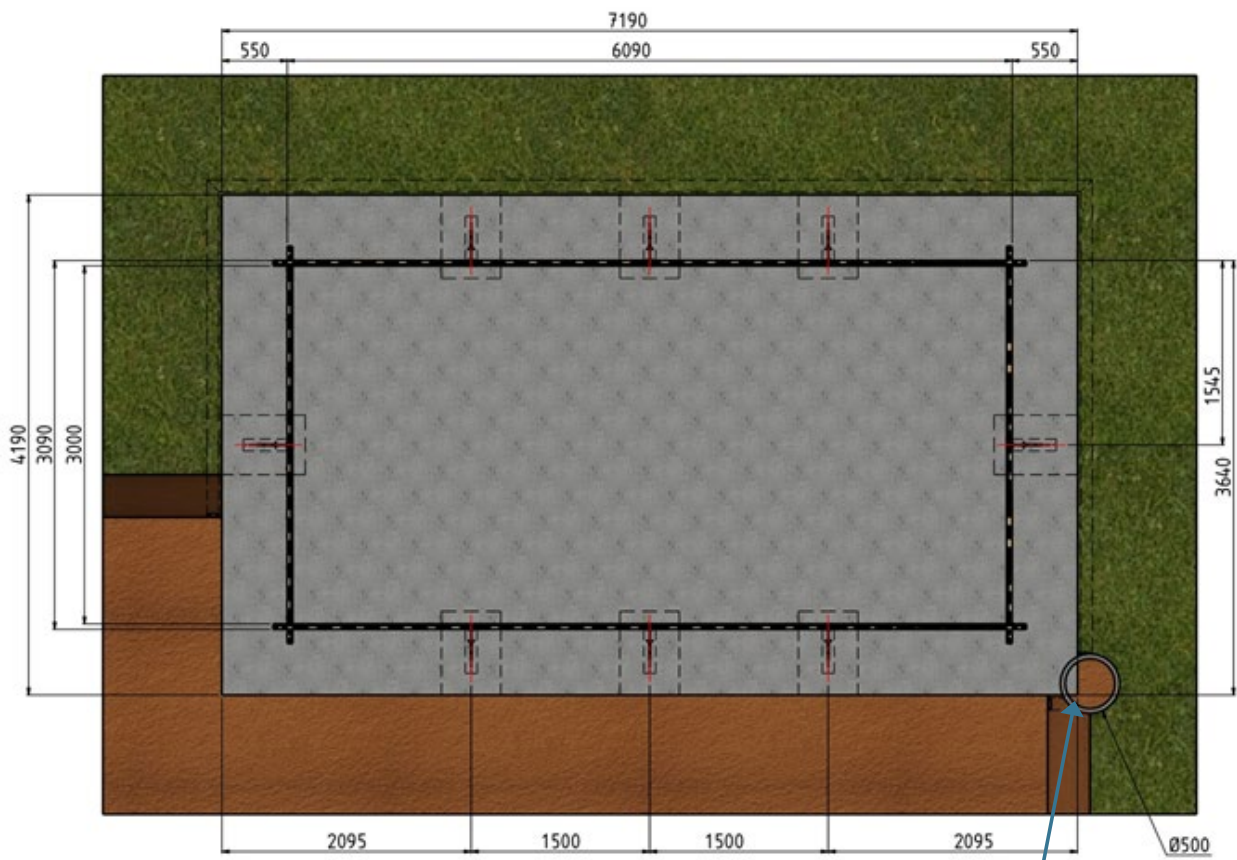
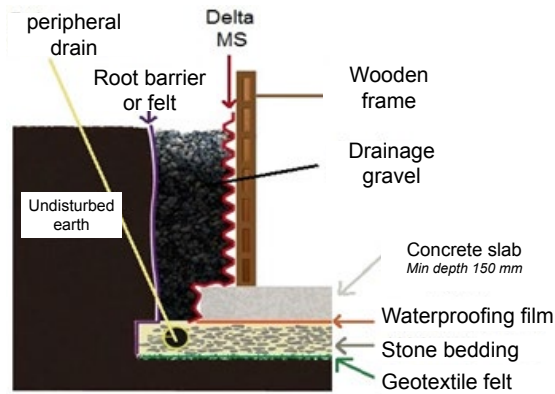
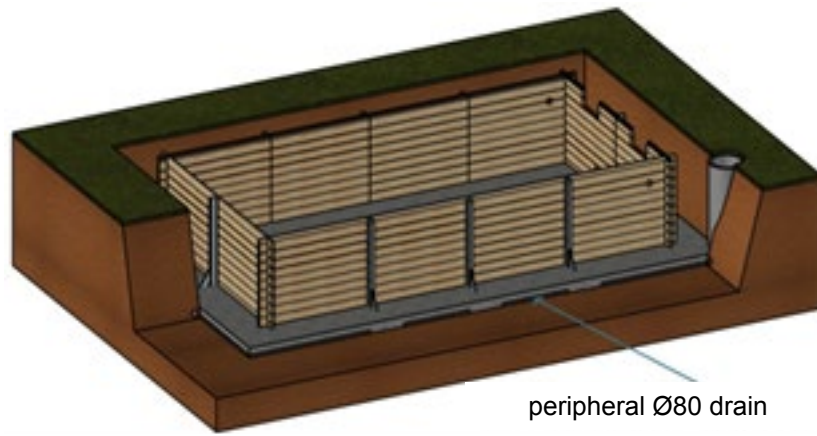

Relief well, 500 mm deeper than the floor of the excavation (outlet of the peripheral Ø80 drain)

Figure 1 – Drainage system installation diagram

5.2.4 Stone bedding

Level the floor of the excavation as much as possible, and then roll out the geotextile to cover the entire floor. Using 20/40 mm gravel lay hardcore to a depth of 110 mm around the entire periphery of the excavation. Correct tamping of the gravel will ensure a neat finish of the excavation floor, and facilitate installation of the supporting braces.

Remove the gravel at the positions shown in *Figure 2* in order to create eight 500 × 650 mm recess 90 mm deep (as measured from the surface of the stone bedding). The recesses will accommodate the steel braces, once imprisoned in the concrete, these braces will support the pool structure.

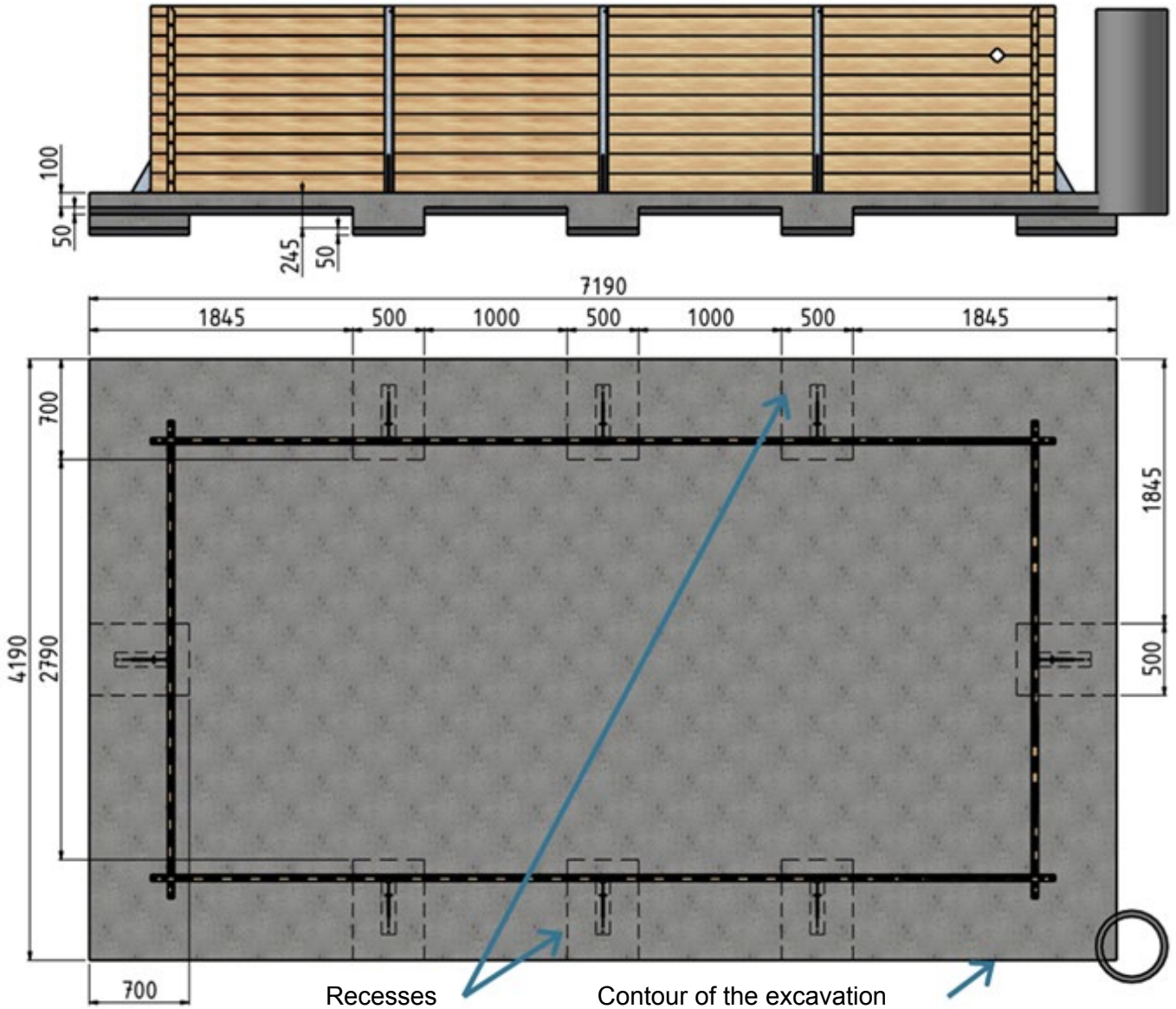

Figure 2 – Positions of the recesses created to accommodate the supporting braces

5.3 Installing the supporting braces

IMPORTANT

The metallic spacers and linking bars for the supporting braces are enclosed in the main wood pack and not the metal pack.

The reinforcing metallic structure is comprised of metal posts joined together at the top and the bottom with flat bars (*Figure 3*). Note how the parts overlap to allow correct positioning of the structure. The flat bars at the top will be removed once the concrete slab has been poured.

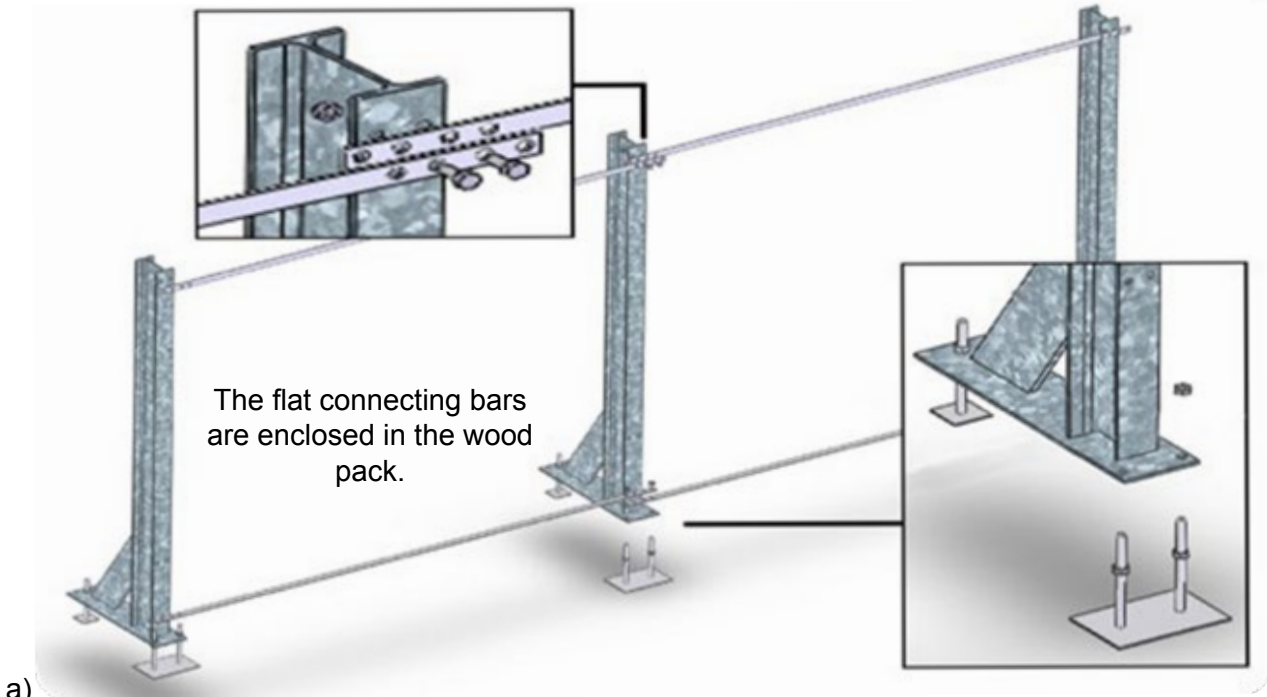

a)

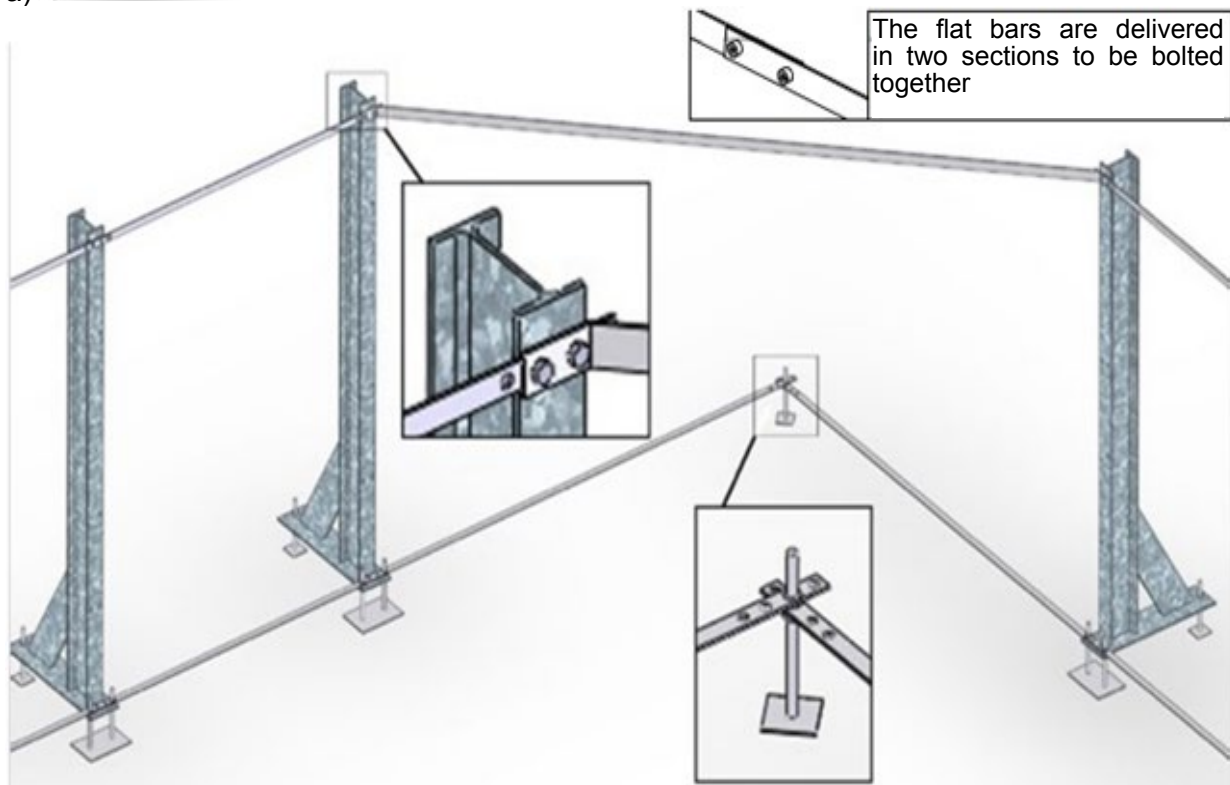

b)

Figure 3 – a and b – Assembling the flat bars on the support braces

Install the supporting braces in each of the eight locations, having first fitted the recesses with jacks (*Figure 3*). Use 8 double acting jacks, 12 single acting jacks and 56 screws with a diameter of 10 mm (bag A). The top screws should be inserted after the height of the bottom screws has been adjusted.

These posts are joined together at the bottom with 12 flat bars (B) 1.6 m long bolted together at 2 points. The distance between each post is determined by these flat bars: it should be 1.5 m. They are joined together at the top by 4 flat bars (B) 1.6 m long (identical to the flat bars at the bottom of the structure) and 4 flat bars (C) that are 2.253 m long in the corners (screw in bag X, see *Figure 3*).

At each end of the flat bars there are four holes. At the bottom, the outer holes should be used to fix them in position, while the inner holes should be used at the top of the structure (*Figure 3*).

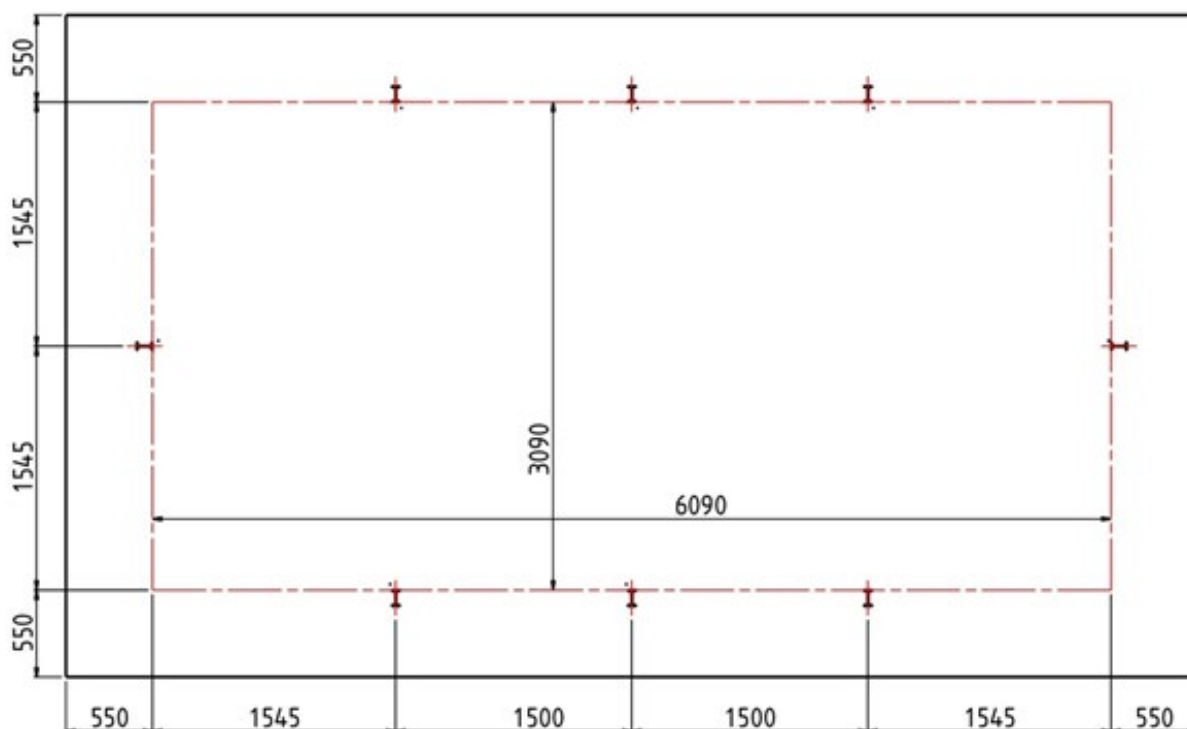
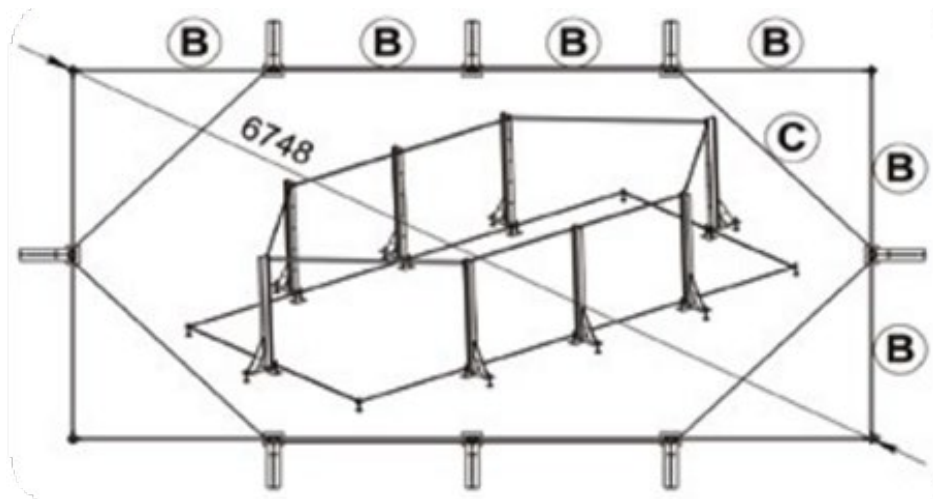

Figure 4 – Position of the support braces and top and bottom connecting bars

! The supporting braces must under no circumstances extend above the top of the pool wall (just beneath the coping) after adjustment of the supporting brace jacks. On the contrary, it is not problematic if the top of the supporting braces are 1 or 2 cm below the top of the pool wall.

After assembly, adjust the supporting braces and check carefully that they are correctly positioned: plumb, level, correct alignment of the supporting braces. To ensure that the supporting braces stay in place after adjustment, you can pre-seal them with a small amount of concrete.

TIP: You can use the supporting braces to visualise how high the concrete slab should be once it has been poured. To do this, taking the top of the pool wall, below the coping, as level 0 measure 1.303 m and mark this distance on the front of the supporting brace. This mark will correspond to the height of the finished concrete slab.

! The height of the pool under the coping may be over 1.303 m if the moisture content of the wood is high at the time of installation of the pool (wood stored in a humid or poorly ventilated area).

! Take particular care while carrying out these assembly steps, they will determine the quality of the pool finish. Incorrect positioning of the supporting braces may render assembly of the pool walls impossible.

! Check that all the dimensions quoted in *Figure 4* are correct before proceeding with the next step.

5.4 Pouring the concrete slab

5.4.1 Rebar

Before pouring the concrete, lay the top layer of welded rebar mesh (type ST25C) over the floor of the excavation (the mesh should be set back 3 to 5 cm from the edge around the entire periphery). Some cutting around the supporting braces will be necessary. The mesh should overlap by one and a half squares and should be connected together using metal ties. The mesh should be raised using spacers to ensure that will sit in the centre of the slab. If you are using self-levelling concrete, you should place a layer of polyethylene sheeting under the rebar mesh because the concrete is very liquid and could flow into the spaces between the gravel. Use C25/30 grade concrete as a minimum.

5.4.2 Slab dimensions

The characteristics of the concrete slab are provided in *Figure 5*. The dimensions of the slab are such the feet of the wooden pool access ladder will not rest on the slab. However, we recommend that the feet of the ladder rest on a solid surface (cement blocks or slab for example).

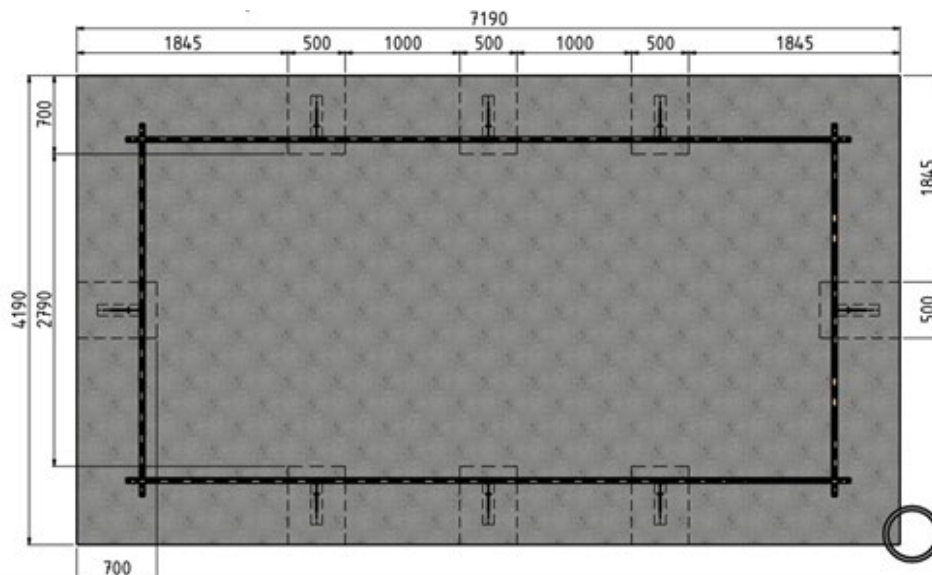

Figure 5 –

The concrete slab

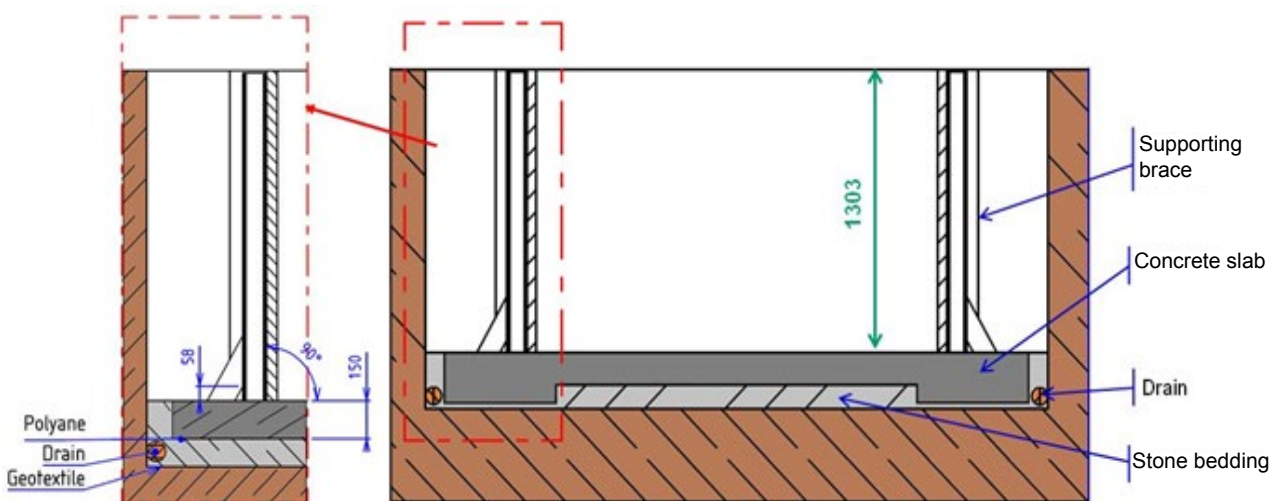

Figure 6 –

Characteristics of the concrete slab

While pouring the slab over the floor of the excavation, make sure that the upper rebar mesh is properly encased in the concrete: the layer of concrete above the mesh must be at least 3 cm thick.

Refer to *Figure 6* to determine the depth of the slab to be poured: it should be 150 mm thick, and of a height to ensure that the distance between the surface of the slab and the top of the excavation is 1303 mm if the pool is to be installed in-ground.

Level and smooth the slab carefully to void surface defects that will have to be corrected later.



The slab provides seating for the wooden structure. Any levelling defects will become apparent when the pool is filled with water. Similarly, significant surface defects will detract from the quality of the finish of the pool floor.

6. ASSEMBLING THE WOODEN STRUCTURE

6.1 Introduction

You may begin assembly of the pool walls 2 to 3 days after the slab is poured without waiting for the concrete to cure completely. However, you must wait at least 3 weeks for the concrete to cure before filling the pool with water.

Before starting to assemble the wooden walls, make sure that the slab is free from any defects and that it is perfectly level. The finish of the concrete slab will determine the correct seating of the walls, the quality of the pool floor and the finish of the pool. A level defect will be accentuated and visible when the pool is filled with water. It could also make it impossible to assemble the pool walls. If necessary, correct defects by sanding or resurfacing the slab.

Your pool is comprised of several slat references, the positions of the slats are illustrated on various diagrams (*Figure 8*). There are specific slats to house the pool fittings (skimmer, return fitting, beam mounting unit and throughwall flange required to mount the automatic cover axle). Assembly of this structure is described step by step in this section.

IMPORTANT

The structural dimensions and measurements listed have a tolerance of +/- 3% (European standard EN 16582-1). The AFNOR AC P90-321 agreement allows the following deviation in terms of depth:

- Depth less than or equal to 1.25m : +/-3cm
- Depth greater than 1.25m and less than or equal to 1.65m : +/-5cm
- Depth greater than 1.65m : +/-8cm



Figure 7 – Urban pool

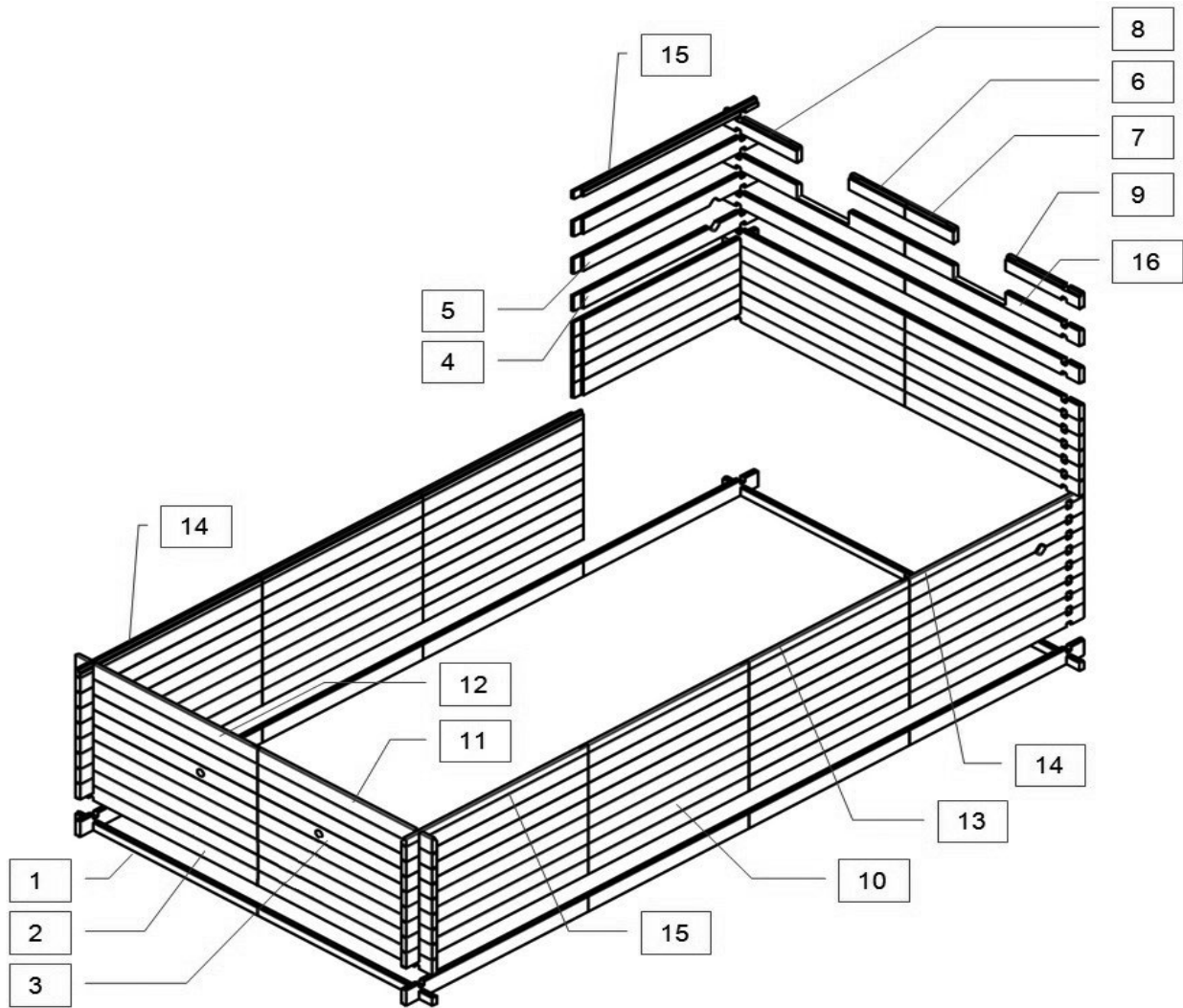

NUMBER	QUANTITY	DIMENSIONS (MM)	TYPE	SPECIFIC
1	4	1700 x 78 x 45	male slat	
2	60	1700 x 145 x 45	male/ female slat	
3	2	1700 x 145 x 45	male/ female slat	return fitting
4	2	1700 x 145 x 45	male/ female slat	throughwall flange
5	2	1700 x 145 x 45	male/ female slat	throughwall flange
6	1	523 x 145 x 45	male/ female slat	left skimmer
7	1	523 x 145 x 45	male/ female slat	right skimmer
8	1	691 x 145 x 45	male/ female slat	left skimmer
9	1	691 x 145 x 45	male/ female slat	right skimmer
10	36	1570 x 145 x 45	male/ female slat	
11	1	1700 x 137 x 45	female slat	left
12	1	1700 x 137 x 45	female slat	right
13	4	1570 x 70 x 45	female slat	
14	2	1700 x 70 x 45	female slat	left
15	2	1700 x 70 x 45	female slat	right
16	2	1700 x 145 x 45	male/ female slat	skimmer

Figure 8 – Exploded view of the wooden structure

6.2 Application of the bituminous strips

Start by unrolling the bituminous strip that will insulate the wooden structure from the concrete slab (*Figure 8*)



Figure 9 – Laying the bituminous strips

6.3 Assembling the slats

Lay out the $\frac{1}{2}$ slats that constitute the pool widths, then, in the corners, slot in the slats that constitute the pool lengths. After laying out the first row of slats, make sure that the diagonals are equal.

Fit the slats together, according to the assembly diagram shown in *Figure 10* and taking care to position the machined slats correctly (see *Figure 8*). The tongues should always be oriented upwards, and the grooves downwards. The slats making up the pool lengths should meet as the metallic supporting braces, as shown in *Figure 11*.

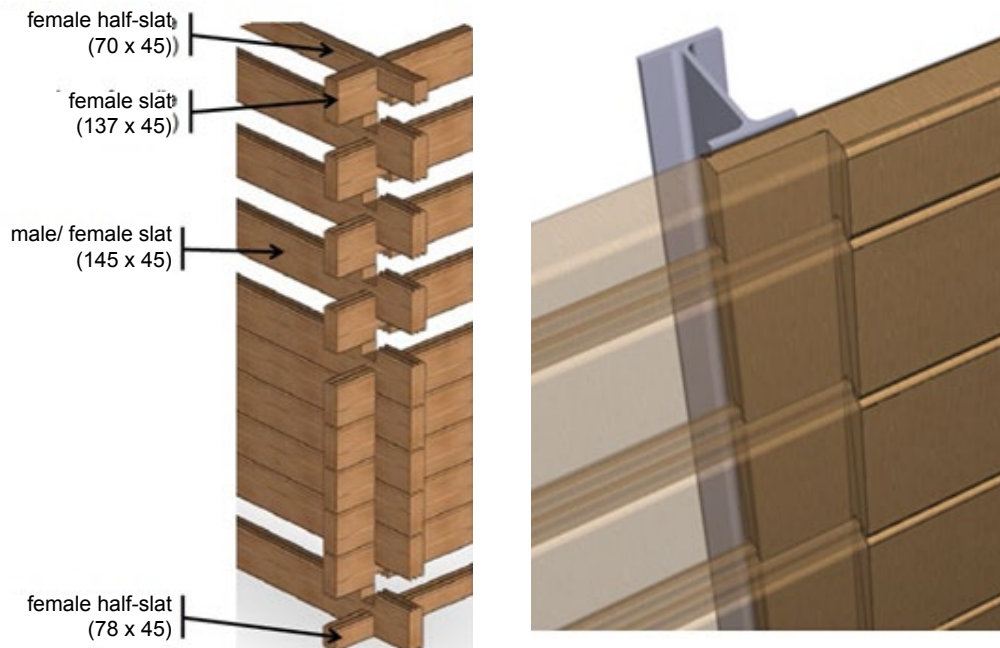

Figure 10 – Slotting together the wooden slats

Figure 11 – Overlapping of slats

! While assembling the pool walls, make sure as of the first rows that the slats are fully engaged in the grooves. After assembling each row, check that the slats are perfectly level. Correct any alignment issues as they arise, to avoid any misalignment of the top of the pool walls. After checking that the slats are perfectly level, and aligned and making any necessary corrections, screw together the slats constituting the pool lengths:

- referring to *Figure 12*, screw the slats together using 2 screws per pair of slats in each of the 10 rows, that is, 160 countersunk screws 5 × 40 A4 SS torx threaded over 25 mm (bag C);
- fix them to the 8 supporting braces (these are pre-drilled as shown in *Figure 13*) using 80 torx safety screws 6 × 30 A2 SS (bag D).

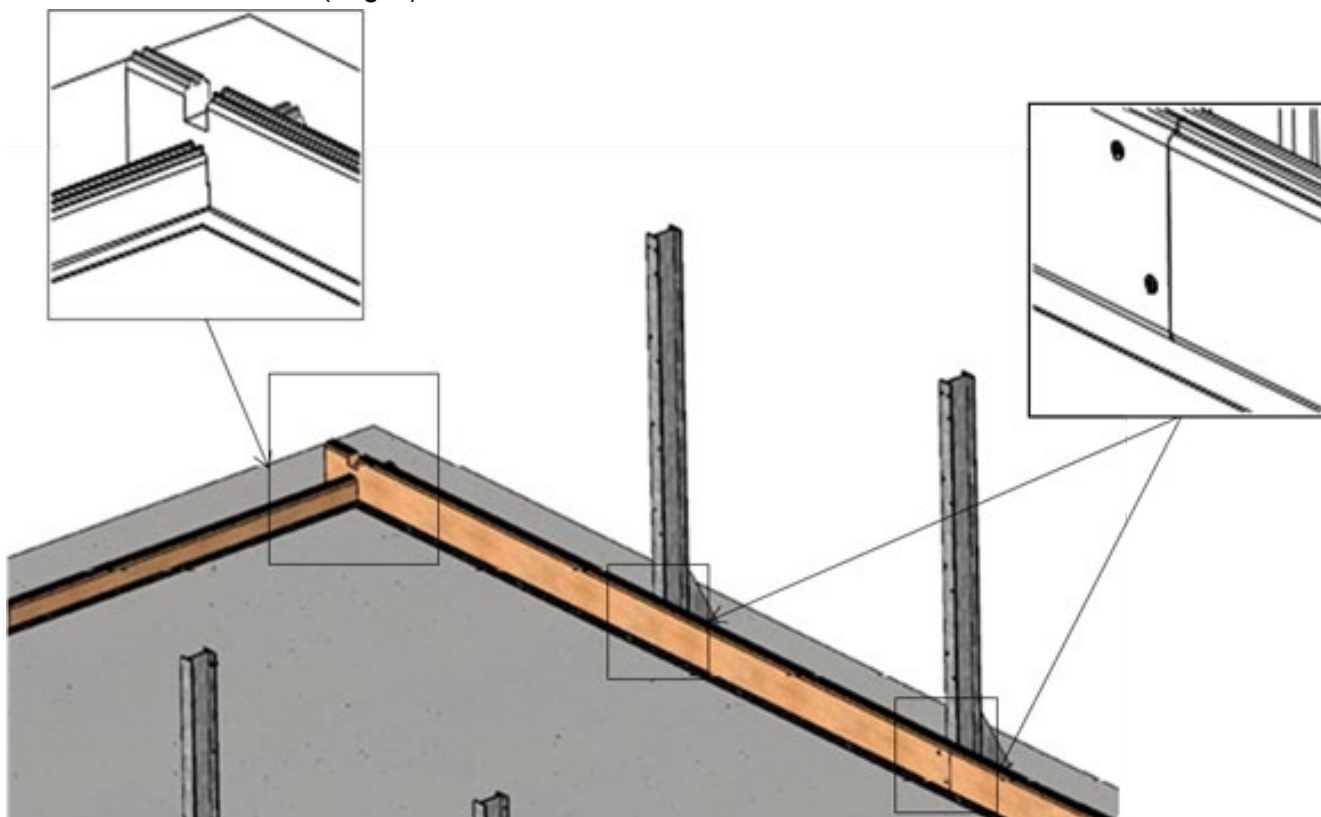

Figure 12 –

Screwing the slats together

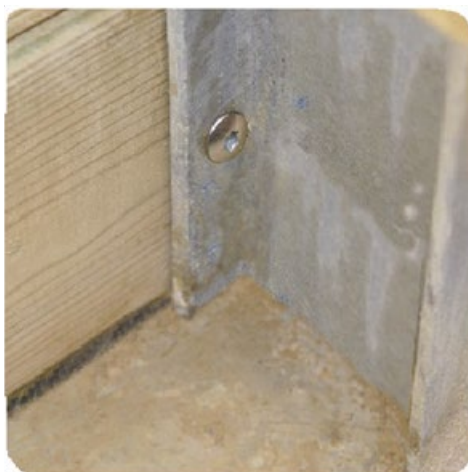

Figure 13 – *Fastening the slats to the supporting braces*

For correct assembly, it may be necessary to use a mallet and clamp to remedy light slat deformations caused by storage. Do not strike the wooden slats directly, use the protective martyr blocks.

- !** The heads of screws inserted from the inside of the pool should be flush with the pool wall to avoid damaging the liner.
- !** The height under the coping of the assembled pool will only be 1.303 m if the moisture content of the wood is normal and the slats are properly fitted together.

Remove any splinters raised by the screws as you go.

6.4 Mounting the finishing trim on the supporting braces

Put the supporting brace finishing trims in position. They should be flush with the top of the pool wall. Working from the inside of the pool, insert screws as shown in *Figure 14* using 3 countersunk screws 5 × 80 A4 SS torx, threaded over 50mm (bag L) per half trim, that is a total of 48 screws. The 2 half trims do not meet, the metallic brace will remain visible.

Should it be necessary to resize the trims (for example, if the pool is installed partially in-ground) orient the cut surface upwards so that the cut side is not in contact with the ground.

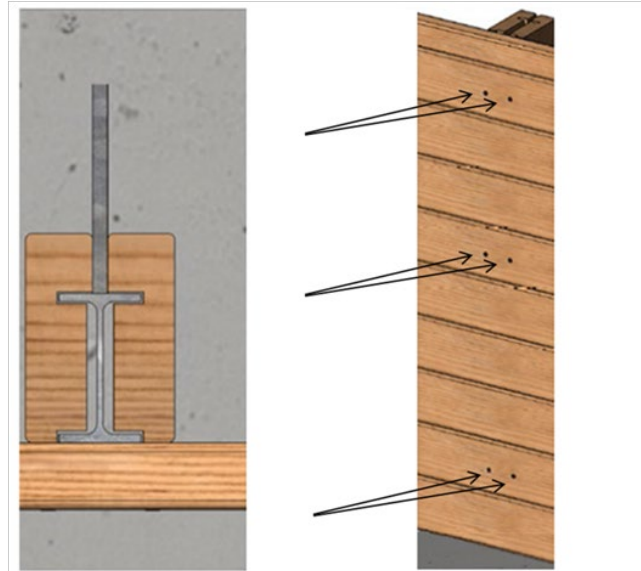

Figure 14 – Mounting the supporting brace finishing trim

6.5 Mounting the coping corbels

Fasten a metallic mounting plate to each of the 14 wooden brackets using 4 countersunk zinc plated screws 5 x 40, torx, threaded over 25 mm (bag M), that is a total of 56 screws, as shown in *Figure 15*: the edge of the width of the metal plate should be aligned with the vertical surface of the bracket that is in contact with the pool wall.

Referring to the diagram provided in *Figure 16* fasten the wooden corbels, furnished with metallic mounting plates, to the pool wall using two screws per corbel, that is a total of 28 countersunk screws, 5 x100 A2 SS, torx, threaded over 60 mm (bag L). The metallic mounting plates should be facing upwards.

In any case, the metallic mounting plates should be flush with the top of the pool wall. Check that the plates are level to allow subsequent mounting of the coping.

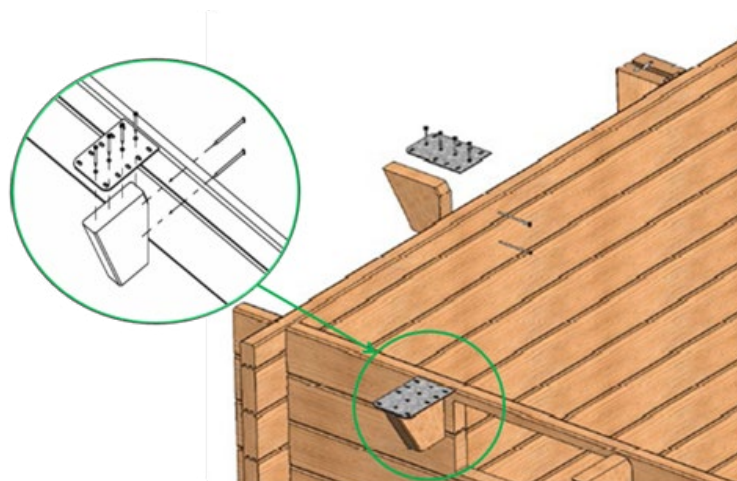

Figure 15 – Fastening metallic plates to the wooden corbels

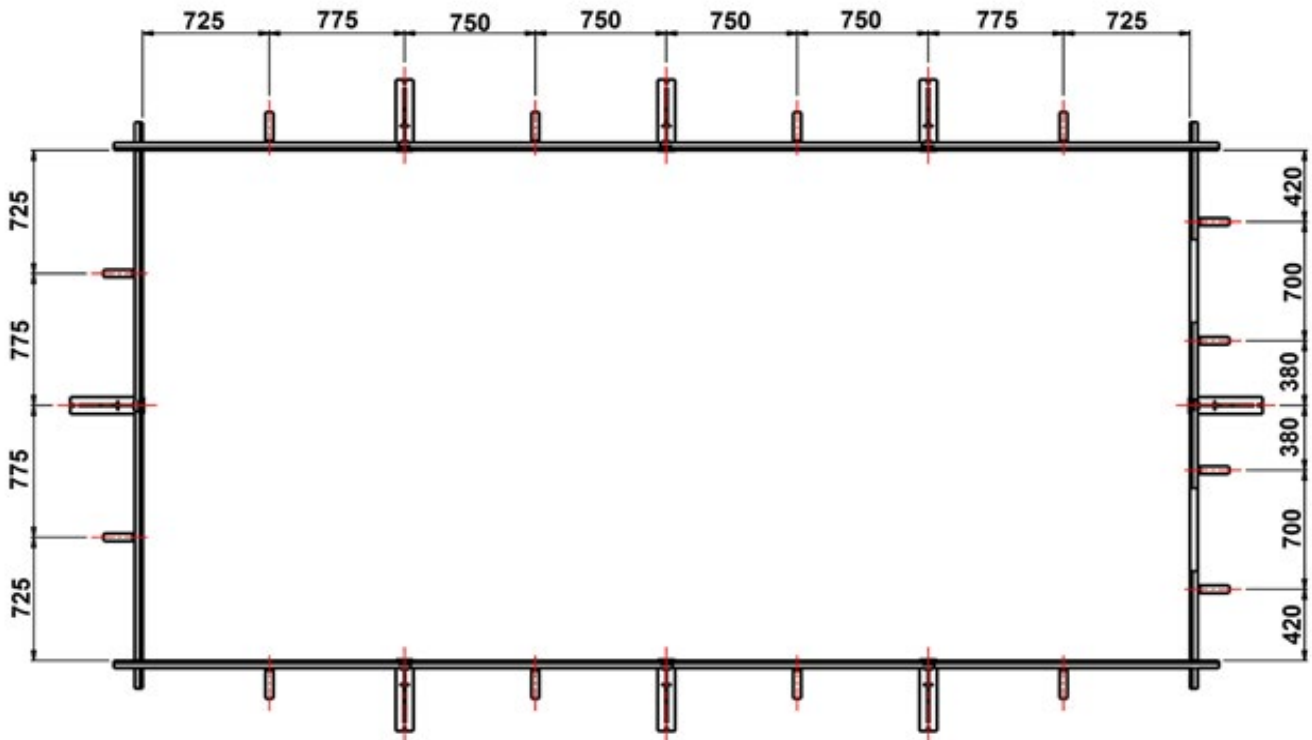

Figure 16 – Coping mounting bracket positions

6.6 Assembling the wooden access ladder

Assemble the ladder according to [Figure 17](#) using 16 zinc plated countersunk screws 5 × 60, torx, threaded over 35 mm (bag K), and fasten the handrail brackets to the right and left hand side of the ladder using 8 SS torx safety screws, 6 x 20 (bag G).

Next, with 8 safety screws 6 x 20, A2 SS (bag G), use the left- and right-hand handrail brackets to fasten the ladder to the pool wall as shown in [Figure 18](#).

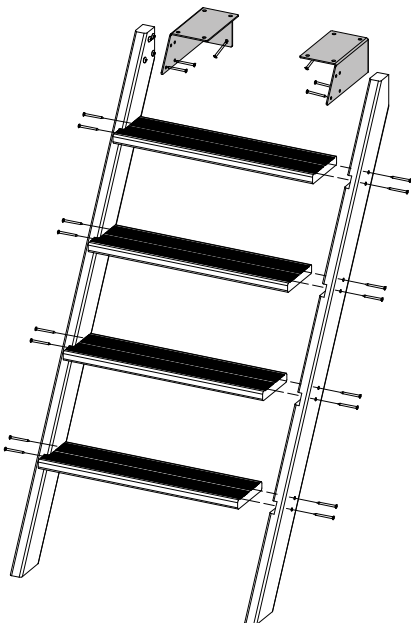

Figure 17 – Assembling the wooden access ladder



Figure 18 – Fastening the access ladder to the pool wall

For your own comfort, we recommend that you mount the ladder on the wall opposite the skimmer. In any case, do not locate the ladder within the third of the pool that contains the automatic cover axle.

The ladder must be located at least 30 cm from the corners of pool. Remember that wooden access ladder and in-pool ladder should face each other.

6.7 Mounting the metal fittings

The metal fittings are intended to support the coping and allow them to be fixed in position. Make sure that they are correctly positioned. They should be flush with the top of the pool wall and aligned with each other and the coping corbel plates. *Figure 20*

- On top of each of the 8 metallic supporting braces and the two wooden supporting braces, place a 'right-hand' fitting and a 'left-hand' fitting from the 'Fastening elements' kit as shown in . Use 6 safety screws 6 × 20 in A2 SS (bag G) per fitting, that is a total of 96 screws.
- In each of the corners, mount a right-hand fitting, a left-hand and a corner fitting as shown in *Figure 20* Use 4 safety screws 6 × 20, A2 SS (bag G) per corner fitting 6 safety screws 6 × 20 in A2 SS (bag G) per fitting, that is a total of 64 screws.

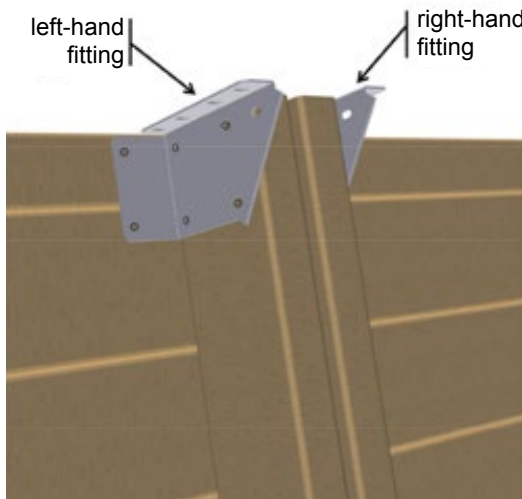

Figure 19 – Mounting the fittings on top of the supporting brace

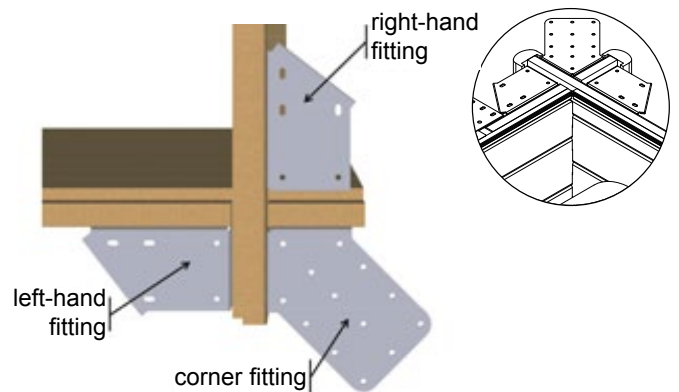

Figure 20 – Mounting the fitting in the corners

6.8 End grain sealer

Using a brush, paint the ends of the slats in each corner with an end grain sealer to limit deformation over time.

This product is white on application, but becomes colourless when dry. Drying time is 2 to 3 hours. If the temperature is high or the drying time is too fast, apply a second coat. Follow the safety instructions on the container. Rinse the brush after use.

6.9 Finishing trim

Use 3 domed head nails, 2.8 x 60 A2 SS (bag I) to fasten the wooden finishing trim to the edge of each wall. The nails should be evenly spaced and the finishing trim should be pre-drilled using a drill bit with a diameter of 4mm. (*Figure 21*).

Apply an adhesive strip (roll provided) to the vertical joints on the inner walls of the pool taking care to ensure that the screw heads are covered (*Figure 22*). This will protect the liner from the screw heads that could damage it.

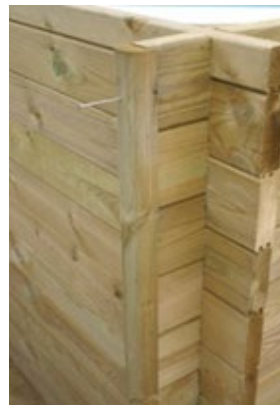

Figure 21 – Wooden trim



Figure 22 – Protective adhesive strip

7. INSTALLATION OF THE FILTRATION SYSTEM

- ! The pump's electrical supply must be protected by a 30mA upstream from the installation.
- ! The filtration system as supplied in the kit, along with all other electrical devices, should be wired in in accordance with the standards in effect in the country of installation.

Do not hesitate to seek the assistance of a professional to ensure the compliance of your installation.

- ! The filter should be installed at a height below the water level. At a height above the water level, there is a risk of deformation due to de-pressurisation. The maximum acceptable height is the level of the coping. If the filter is installed above the water level, a check valve must be mounted on the return fittings and an easily accessible check-valve should also be installed on the suction line (these items are available from pool suppliers).

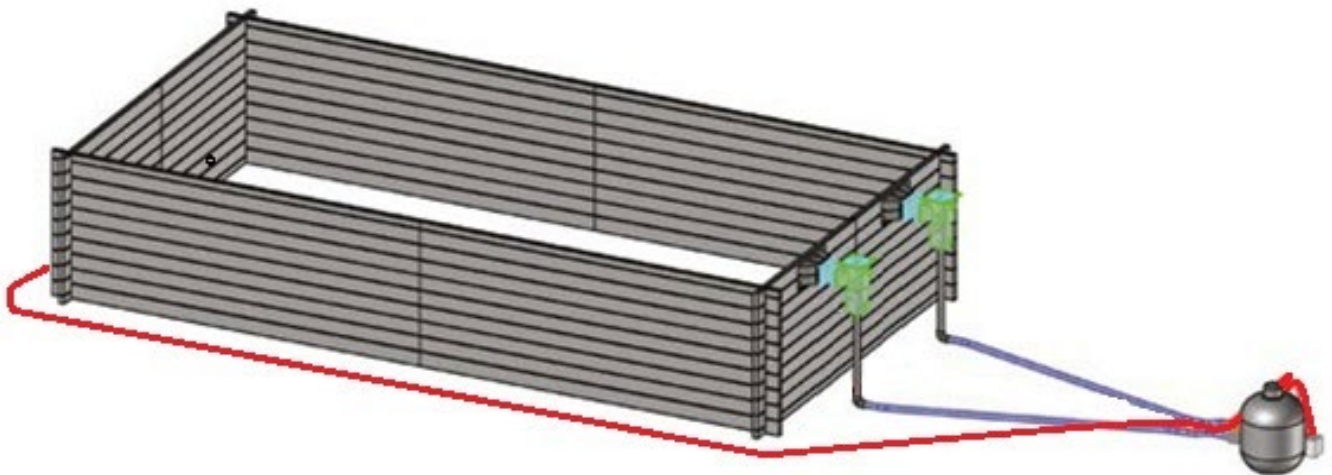

Figure 23 – Proposed position of the filtration group

The installation described is a sample installation, the kit provided allows for installation of the filtration group at a distance of 3.5 m from the pool in accordance with standards in effect. It may be necessary to adjust the pipe lengths depending on the configuration of the installation site, the type of installation (above-ground, partially in-ground, in-ground), the type of plant housing and other restrictions imposed by the installation.

Refer to the instructions for mounting the sand filter provided below, and the pump's operating instructions. Note the sketch of the filtration system that shows all the various components and connection information.

DESCRIPTION	FLOWRATE, NO DIRECTIONAL JET ON THE RETURN FITTINGS	FILTER DIAMETER	SAND	FILTRATION SURFACE AREA	VOLUME FILTERED IN 24 HOURS
URBAINE 6.5 × 3.5	6 m ³ /h	500 mm	2 × 25 kg	0;2 m ²	232.8 m ³

7.1 Filtration group components

The various components of the filtration group are listed below.

7.1.1 Rigid module

REF	Description
A	Suction module (rigid descent)
B	Union under the skimmer
C	Return module (rigid descent)
D	"Y" module for return fittings

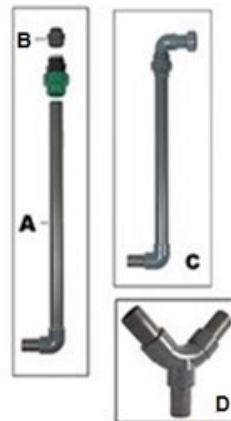

7.1.2 Return fitting

REF	Description
O1	Body
O2	Seal
O3	Flange
O4	Directional jet

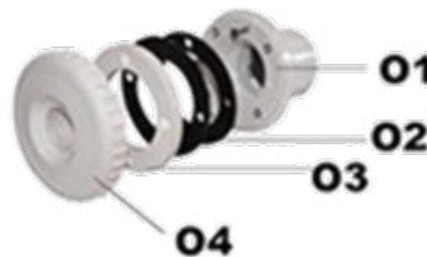

7.1.3 Skimmer

REF	Description
I1	Lid
I2	Basket
I3	Flange seal
I4	Screw 5.5 x 25
I5	Flange
I6	Weir
I7	Flange trim
I8	Lid housing
I9	Blanking cap
I10	Crush resistant pipe
I11	Body

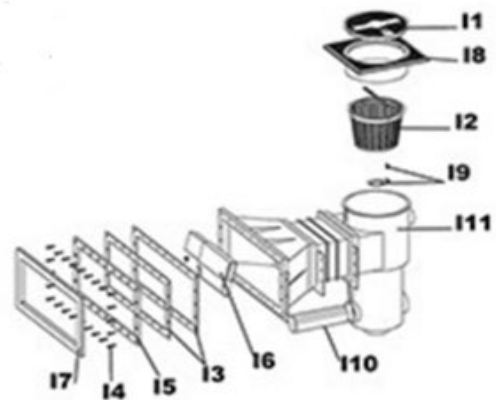

7.2 Skimmer

When mounting the ABS fittings, do not over-tighten, this could fracture the parts. Tighten the screws by hand. Make sure that seals have been correctly positioned and correctly applied. Once the liner has been fitted, it will be difficult to correct a forgotten step or mistake.

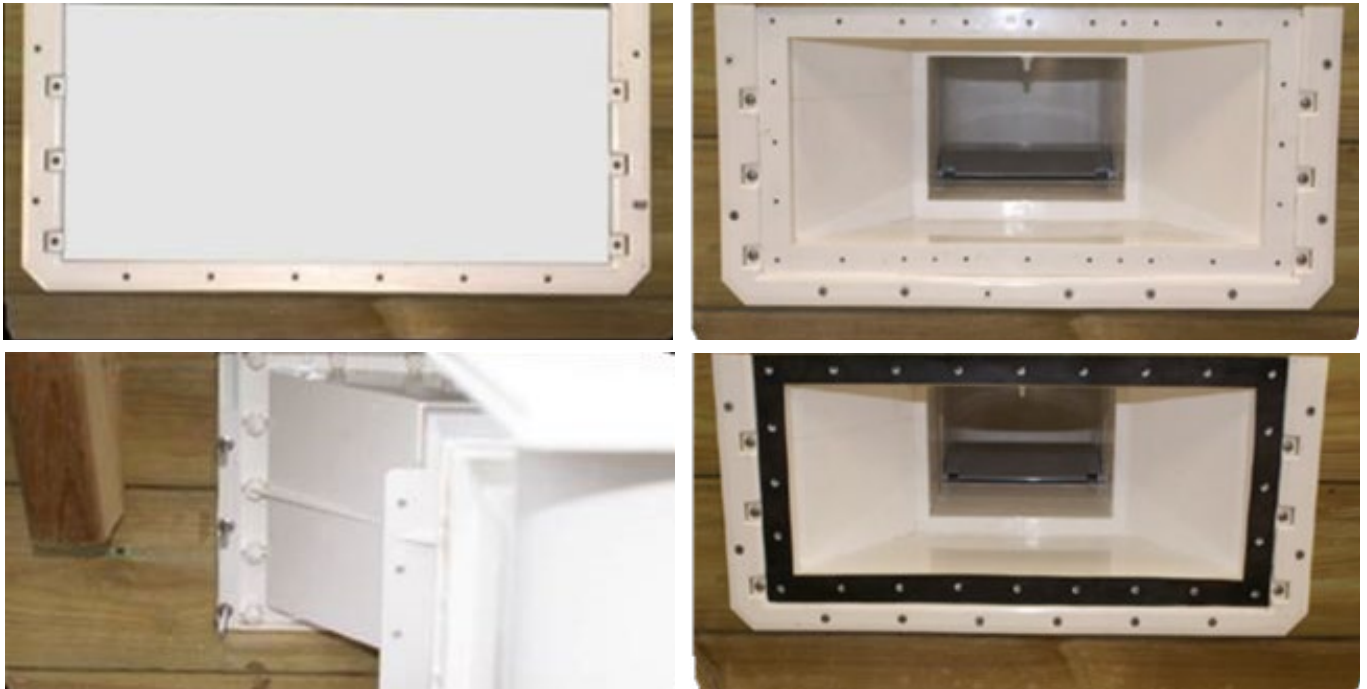

Figure 24 – Assembly of the skimmer

First, mount the prefix flange on the skimmer using the countersunk wood screws 3 × 25 (these components can be found in the pool fittings skin pack).

Mount the grey tube, external diameter 63 mm on the skimmer body (*Figure 25*). Push it in fully, but do not use glue. This tube will wedge the skimmer, holding it in its vertical position against the wooden wall.

Put the skimmer in position, making sure it is properly mated against the prefix flange. Fasten it in position using the countersunk screws 5 × 16, and the associated washers and nuts.

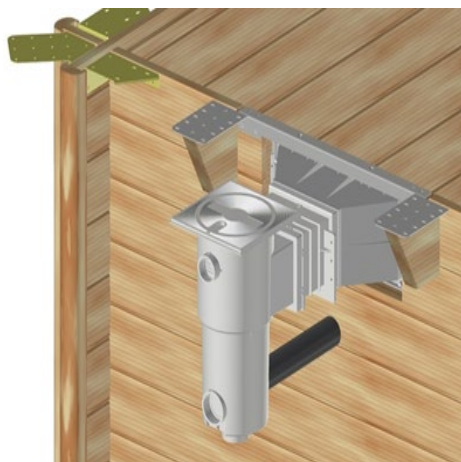

Figure 25 – Mounting the skimmer bracket

Glue the first self-adhesive gasket (pool fitting skin pack) in position, making sure that the holes in the skimmer and the gasket are correctly aligned.

As shown in *Figure 25* fit the metallic bracket over each skimmer to block it in position. Fasten the brackets to the wall using 16 countersunk screws 5.5 × 25 SS A4 (bag M).

Glue the skimmer seals to the front face, taking care to ensure that the holes in the skimmer and gasket are correctly aligned. The liner must be fitted within the next 48 hours *paragraph 10.1, page 42*. If this is not possible, delay mounting the gasket until just before the waterproofing membrane will be fitted. The rest of the part (gasket and flange) will be added after the liner has been fitted to ensure a leaktight finish around the skimmer.

7.3 Return fitting body

Working from inside the pool, push the return fitting body into the opening in the machined slat (*Figure 26*). Fasten it to the wall using 8 countersunk pozidrive wood screws, A4 SS (bag of screws enclosed with the return fitting).

Apply the self-adhesive gasket to the throughwall flange. As in the case of the skimmer, the liner must now be fitted within the next 48 hours. If this is not possible, delay application of the gasket until just before the waterproofing membrane is fitted. The rest of the part (gasket and flange) will be added after the liner is fitted to ensure leaktightness at the return fitting.



Figure 26 – Mounting the return fitting body and gasket

7.4 Filtration pipework

No tools are required to tighten the barrel unions (isolation valves), they should be hand tightened only: over tightening could damage the threading on the unions or the gaskets, leading to leaks. Use 3 or 4 turns of sealing tape on connections with no gaskets.

Only the collar clamps (cerflex) need to be tightened with a flat head screw driver. Take care not to overtighten. Do not forget to thread the protective rings that will go over the collar clamps onto the pipe before tightening.

7.4.1 Installation of the rigid descending modules

- ! Apply Teflon to the various connections where appropriate and check that all gaskets are in position.
- ! While installing the rigid descending pipe, you can orient the lower section to facilitate subsequent installation of the pipes.



Union under the skimmer



Rigid descending pipe under the skimmer

Screw the unions B under the skimmers, do not forget to wrap teflon around the 2 threadings.

Cut the pipe at the mark corresponding to the height of your pool. Chamfer the cut slightly to facilitate insertion of the pipe into the compression union. Check that the pipe is inserted fully then tighten the green barrel union taking care to ensure that the connection is leaktight. Screw the rigid descending pipe to the union under the skimmer.

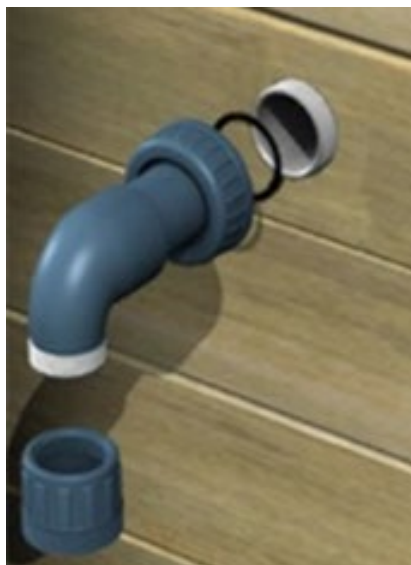

Elbow union on the return fitting



Rigid descending pipe under the return fitting

Screw the rigid descending pipe C onto the return fitting nozzle elbow, do not forget to check that the o-ring is in position. Cut the vacuum fitting rigid descending pipe (as described above and according to the height of your pool) and install it.

After wrapping teflon (accessories skin pack) 4 or 5 times around the rigid descending pipe elbows C (return fittings), screw them onto the nozzle outlets, do not forget to put the o-rings provided in the pool fittings skin pack into position. Hand tighten to avoid crushing the o-ring. Next, screw the upper union of the rigid descending pipe onto the two return fitting elbows.

8. ASSEMBLING AND COMMISSIONING THE FILTER GROUP

Before you continue to fill the pool, assemble the filtration group. Refer to the sand filter installation instructions below and the pump operating instructions. Study the filtration system diagram and the table below that lists the main components and the composition of the various packs.

The filtration system, like every other electrical device, must be wired in accordance with the standards in effect in the country of installation (C15-100 in France).

Do not hesitate to call on the services of a professional to ensure that your installation complies with all regulation in effect.

Do not hesitate to call on a professional to guarantee the compliance of your installation.

We strongly recommend that you install the filter below the water . If the filter is installed above the water line, there is a risk of deformation due to depressurisation. The maximum acceptable height is level with the coping. In the event that the filter is installed above the water line, a check vent must be mounted on the return line and an inspection check valve must be mounted on the suction line (these items are available from any pool specialist).

8.1 Filtration components components and specifications

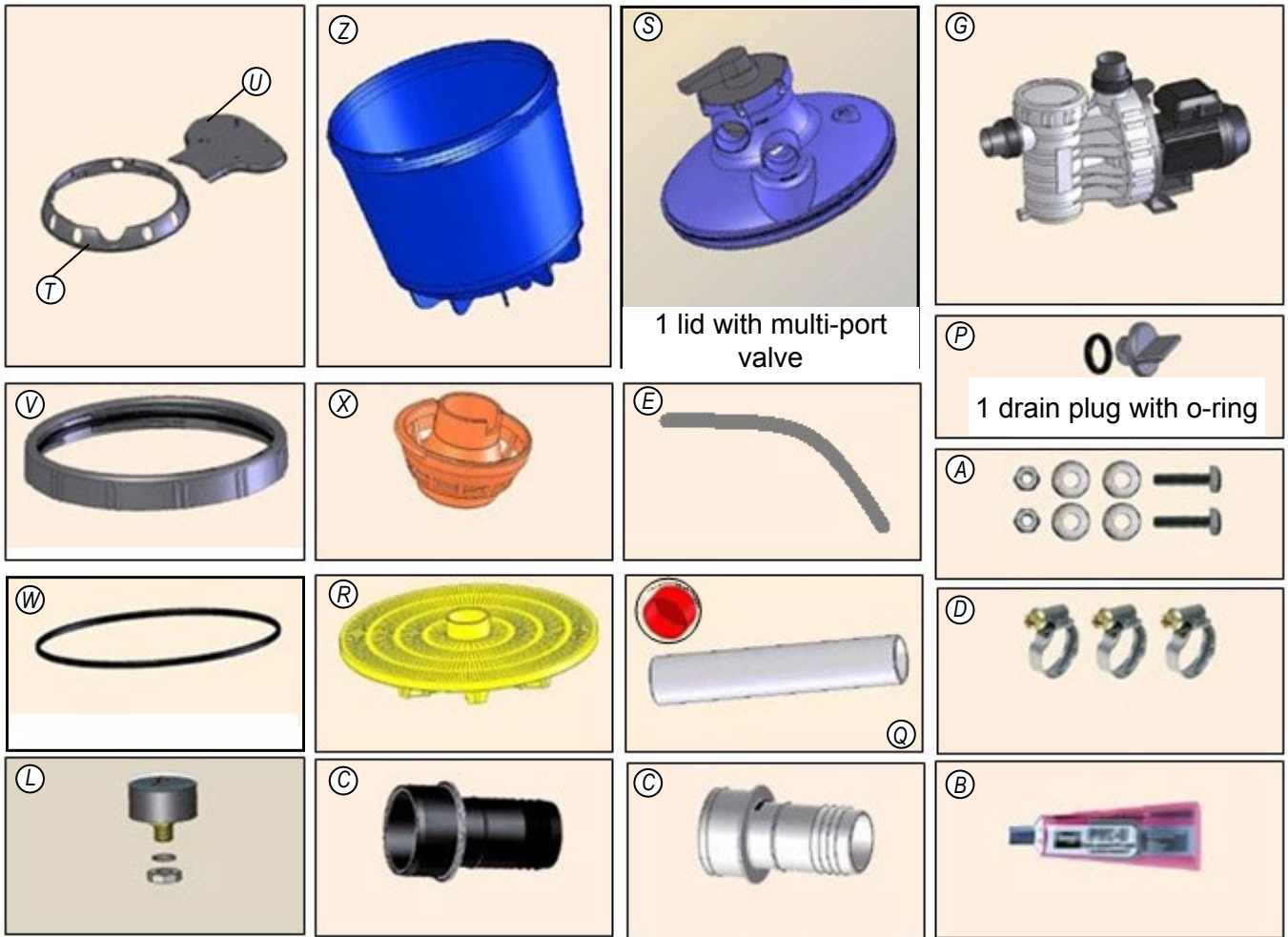

ref	DESC
A	SCREWS
B	TUBE OF GLUE AND TUBE OF SILICON
C	HOSE TAILS
D	RUBBER SLEEVE + CIRCLIPS
E	PUMP/ FILTER CONNECTOR HOSE
F	SUCTION ISOLATION MODULE
G	PUMP
K	RETURN LINE ISOLATION MODULE (VALVE)
L	PRESSURE GAUGE
P	DRAIN PLUG
Q	PVC TUBE AND CAP
R	FILTER FLOOR
S	LID+ 6 WAY VALVE
T	FILTER BASE
U	PUMP BASE
V	BELT
W	TANK O-RING
X	DIFFUSER
Z	TANK
F	The type of collector manifold will depend on the number of skimmers



8.2 Assembling the filter

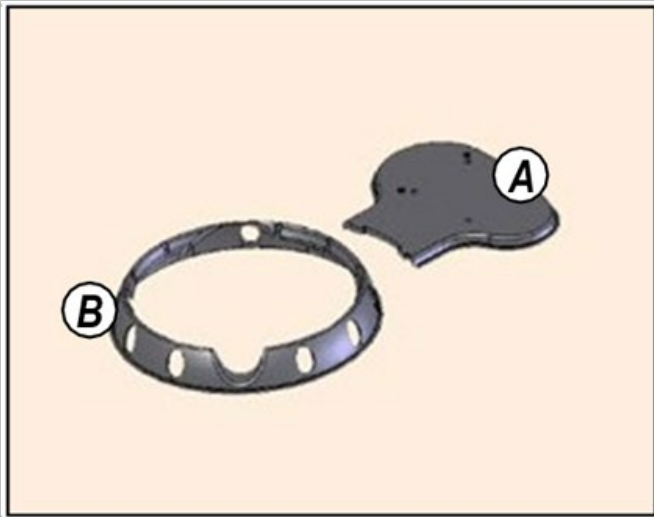

Assemble the base by clipping the 2 tabs on the pump base (A) into the notches on the filter base (B).

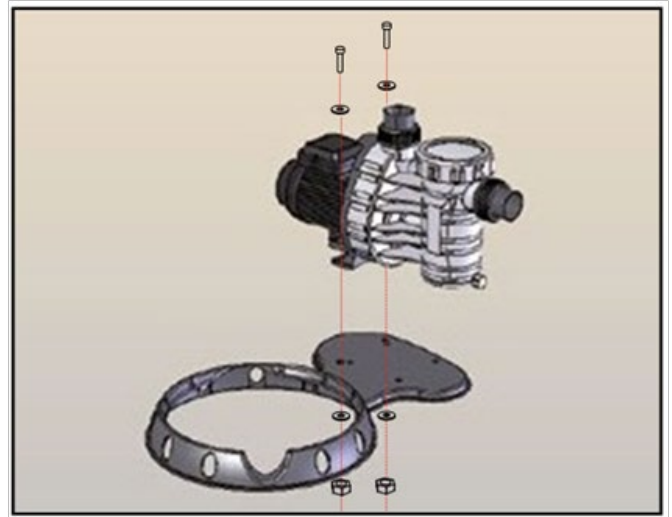

Place the pump on the base and fix it in position using 2 screws, washers and nuts.



Check that the drain plug and o-ring are in position. Hand tighten only.

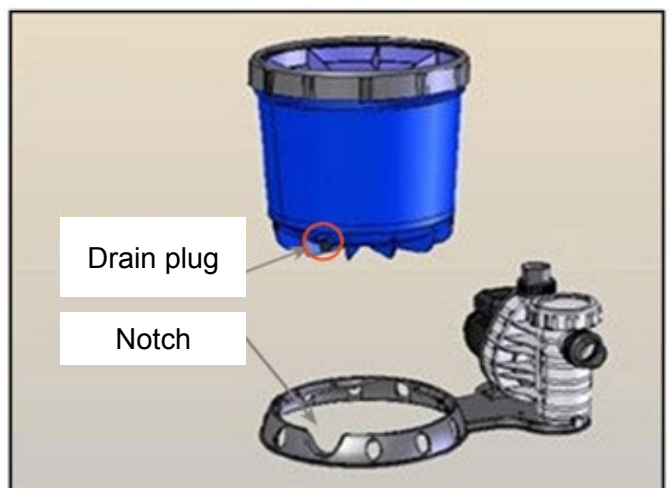

Place the filter on its base, making sure that the drain plug fits into the notch in the base.

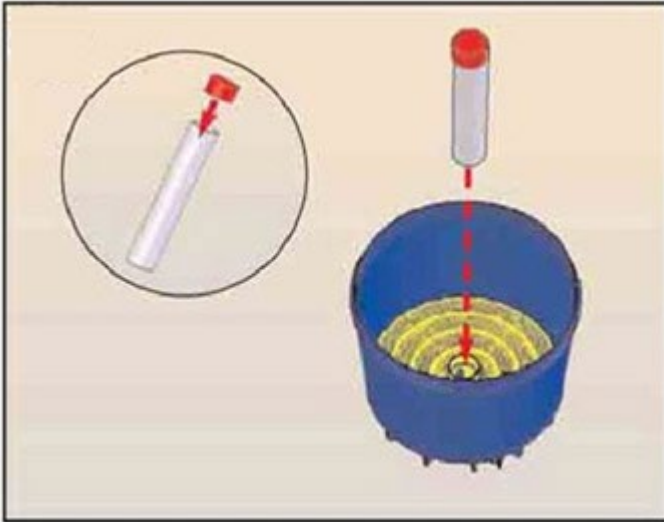

Place the cap on the collector pipe and insert it into the hole in the middle of the collector plate.

Pour the sand filter medium carefully into the tank, use your hand to spread it out evenly.

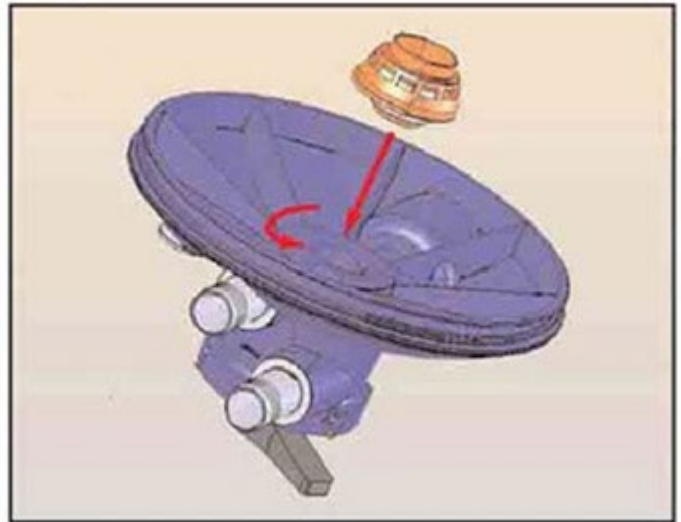

Insert the diffuser into the lid and rotate it anti-clockwise to lock it in position.

The filter lid features 3 ports. Mount the relevant union on each port:



S1	Outlet port: 38 mm hose tail
S2	Pump suction: 45 mm hose tail
S3	Return fitting: Tapped sleeve 1"1/2 x male, solvent, 50 mm



Installing the pressure gauge:
Place the o-ring in its groove in the cover.

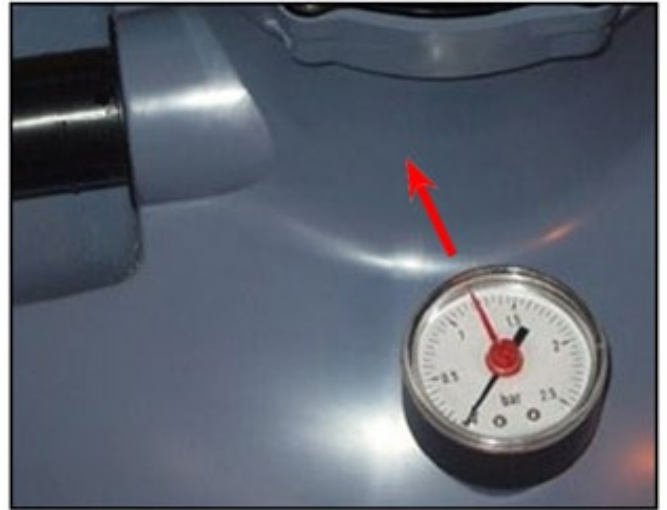

Position the pressure gauge correctly and place it in its housing.

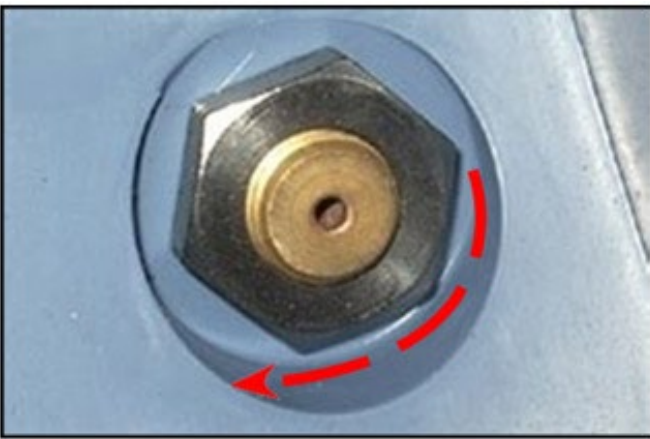

Working from underneath the cover, tighten the bronze nut by hand, then moderately using a 22 tube wrench. Take care not to damage the o-ring.

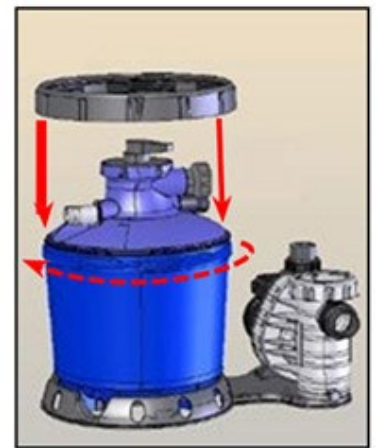
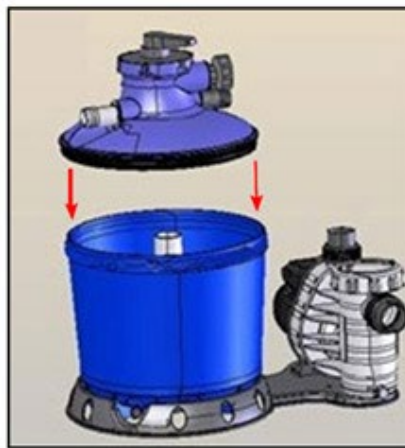

Fit the o-ring into the groove in the lid.

Check that the upper, inner section of the tank is clean.

Remove the cap from the collector pipe.

Orient the lid such that the Pump and Return port are facing the pup return union.

To facilitate fitting the lid, apply a lubricant (silicon grease) to the inner surface around the top of the tank.

8.3 Instructions for fitting the filter lid



Hold the lid over the filter tank.



Press the lid into the filter tank at one point. Using your knee, maintain pressure on this point



Position your two hands on the lid such that they are equidistant both from each other and your knee (120° angle)



Bear down simultaneously with both hands to push the lid completely into the filter tank. Maintain pressure on the lid until the ring is screwed into position..

Once it is properly fitted the lid should touch the top of the tank and the o-ring should not be visible. Put the lid ring into position to hold the lid on the tank. Rotate one quarter turn by hand only.

CAUTION : AN IMPROPERLY FITTED LID COULD LEAD TO :

- Sand being introduced into the pool through the return fitting,
- Water leaking from the waste port,
- Leaks from the tank.

It is normal for a small amount of water to escape from the waste port in filtration mode. To limit water loss, we recommend that you mount a 1/4 turn valve on the waste line (not supplied).

8.4 Pump filter & collector module

Assemble the pump. Orient the assembly to facilitate subsequent connection of the semi-rigid pipes leading to the pool.

Screw the isolation module (F) to the pump inlet port. The type of module will depend on the number of intake modules (skimmers and vacuum points). Do not forget the o-ring enclosed in the pump pack.

Mount the screwed union onto the pump outlet port (do not forget the o-ring). Trim the pipe to the correct length and connect it as illustrated between the pump and the 6-way valve.



8.5 Connecting the pipes

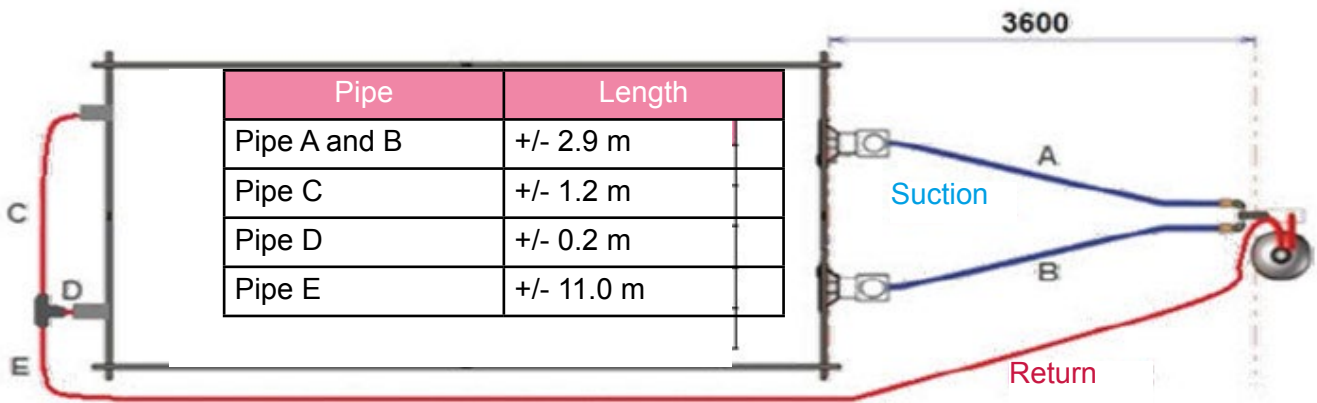

Connect the pipes as shown between the rigid descending pipes and the filtration group.

The filtration kit enclosed with your pool is sized for installation of the filtration group 3.5 m from the pool, as are the lengths of the pipes. They may need to be modified to fit your installation.

Once the hydraulic connections are made, check that all the valves are CLOSED.

9. PARTS FOR THE AUTOMATIC COVER

9.1 Throughwall flange

The throughwall flange holds the axle in the pool wall and allows transmission of rotation between the motor and the automatic cover axle. It should be mounted on the same side as the skimmer, as shown in *Figure 27*.

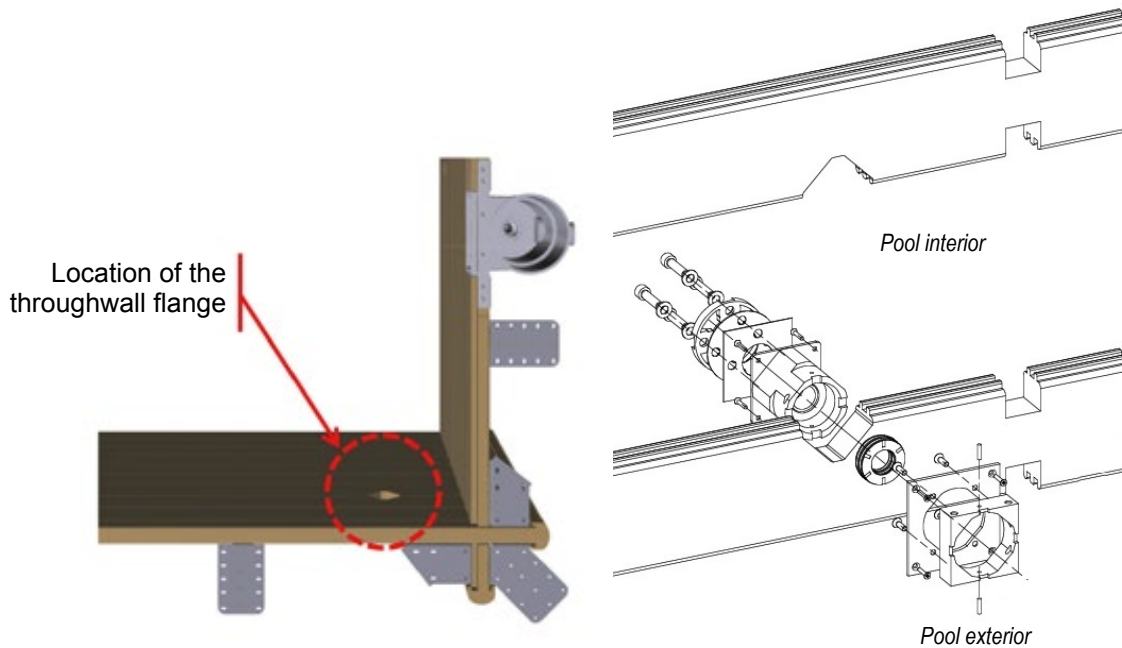

Figure 27 – Position of the throughwall flange

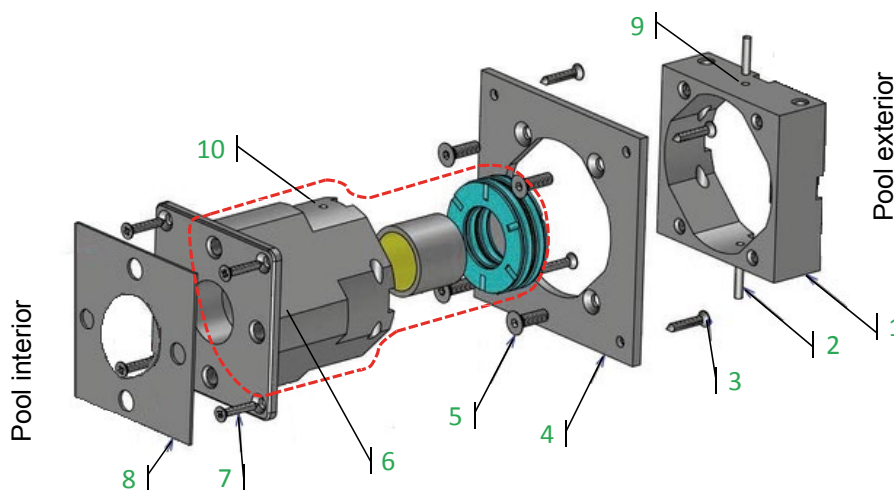

Figure 28 – Mounting the throughwall flange

Assembly of the throughwall flange is set out step by step below. The numbers referred to are those highlighted in green in *Figure 28*. The screws are provided in the bag enclosed with the throughwall flange.

- Working from inside the pool, put the throughwall flange (6), which is a collection of three parts pre-assembled in the factory. Fasten it to the wooden pool wall using the 4 cross-head countersunk screws 4.2 × 25 A4 SS (7) ;
- Attach part 1 to part 4 in the wood using four cross head countersunk screws 4.2x25 four FHC screws; 6 × 20, A4 SS (5). Working from outside the pool, attach this assembly to part 6, making sure that the holes (10) in part 6 are correctly aligned with the holes (9) in part 1. Insert the two 4 mm diameter, 20

mm long, pins (2) in these holes ;

- Attach part 1 to part 4 using in the wood using four cross head countersunk four A4 SS screws 4.2 x 25mm (3).
- Apply the adhesive gasket (8) to the body of the throughwall flange (6) making sure to align the holes in the part with the holes in the gasket. The liner must be fitted within the following 48 hours (step 9). If this is not possible, delay mounting the gasket until just before the liner is fitted. The rest of the part (gasket and flange) will be added after the liner is fitted, this will make the throughwall flange leaktight.

9.2 Bearing mounting unit

The purpose of the bearing mounting unit is to hold the axle in the pool wall opposite the motor and allow rotation of the axle.

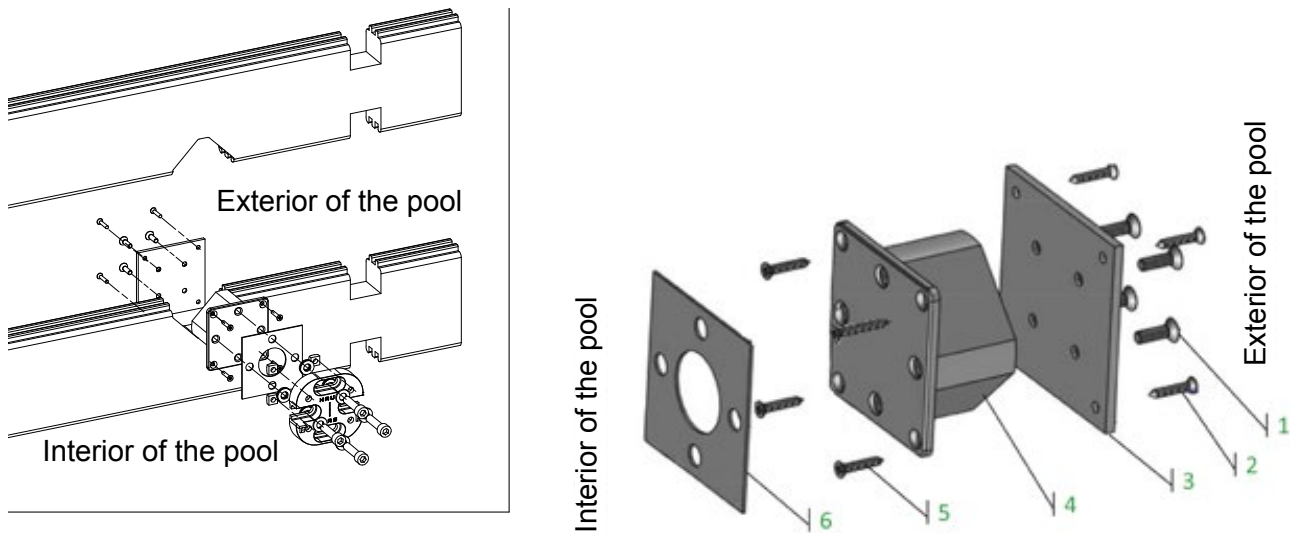

Figure 29 – Mounting the bearing support unit

Assembly of the bearing mounting unit is set out step by step below. The numbers referred to are those highlighted in green in [Figure 29](#). All the screws are provided in the bag enclosed with the throughwall flange.

Working from inside the pool, put the bearing mounting unit (4) in position, fasten it to the wooden wall using 4 cross-head countersunk screws 4.2 × 25 A4 SS (5).

Working from outside the pool, fasten the counter plate (3) to the body of the bearing mounting unit (4) using four socket head countersunk screws 6 × 20 A4 SS (1). Next, screw the counter plate to the wooden wall using 4 cross-head countersunk screws 4.2 × 25 A4 SS (2).

Lastly, glue the adhesive gasket (6) to the body of the bearing mounting unit (4) making sure that holes in the gasket are correctly aligned with the holes in the part. The liner should be fitted within the next 48 hours ([Paragraph 11, page 43](#)). If this is not possible, delay applying the gasket until just before the waterproofing membrane is fitted.

The rest of the part (flange and gasket washers) will be added after the liner is fitted in order to ensure leaktightness at the bearing mounting unit.

10. IN-POOL LADDER

Assemble the ladder as shown in *Figure 30*. The numbers referred to are those highlighted in green in this diagram.

10.1 Assembling the in-pool ladder

Start by mounting the ABS treads (3) on the aluminium tubes (1) using the 6 aluminium screw, washer and nut assemblies (diameter 8 mm) (12, 13 et 14). Only use aluminium screws, using screws other than aluminium screws could lead to a risk of galvanic corrosion. If necessary, tap the screws (12) in using a mallet or a hammer and martyr block, taking care not to damage the aluminium tube.

Install a ball (2) at each end of the two tubes, then insert the balls on the bottom into the protective bumpers (10), that will allow you to use the ladder without damaging the liner.

Attach the two supports (4) just under the first tread by screwing them to their shells (7) using four A4 SS screws 6 × 40 (9) and washers. Do not over-tighten, the enclosed tube should be able to slide up and down to allow the support to be positioned opposite a full slat and not straddle two wall slats.

10.2 Drilling holes to mount the ladder

- Position the ladder in the pool, centring it opposite the wooden access ladder that was assembled previously. The bumpers should rest against the pool floor ;
- Trace the position of the ladder supports (4) on the pool wall, on a full slat ;
- Remove the ladder and use the gasket (11) to mark the position of the two holes through which the screws (5) will be inserted ;
- Next drill the four 10 mm diameter holes in the pool wall to fasten the ladder in position after the liner has been fitted.

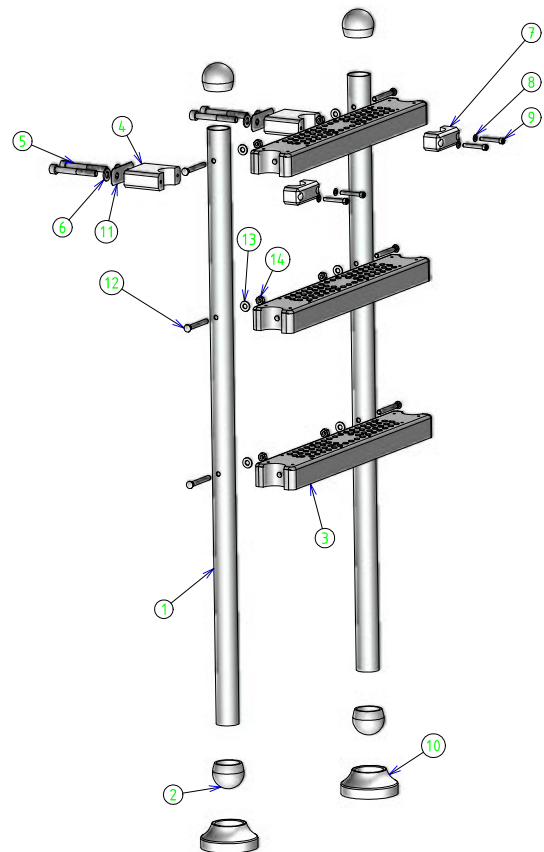

Figure 30 – Assembling the ladder

11. FITTING THE WATERPROOFING MEMBRANE

11.1 Installing the liner locking track

Before starting to install the liner locking track, make sure that the structure has been correctly assembled. To do this, check that the entire periphery is horizontal (use a spirit level), and that the diagonals are equal in length. If not, rectify these imperfections before continuing.

Start installation of the liner locking track in a corner. Continue around the periphery of the pool, taking care with the joints between each 1.18 m length of track. Each section of track must be perfectly aligned with the two adjacent sections of track to avoid damaging the liner. Joints between sections of liner locking track do not need to coincide with the structure's supporting braces.

It may be necessary to trim the track at the end of a length or width: to do this, measure the distance to be covered and cut a bar to that length. Remember to deburr the track after trimming.

The track should be flush with the top of the wooden structure. Before fixing the liner tracking track into position, pre-drill the track using the 4 mm diameter drill bit provided (bag J). Insert the screws provided at approximately 20 cm intervals (countersunk screws 4 × 35, torx, threaded over 20 mm in A4 SS, bag H). Do not overtighten, to prevent screws from passing completely through the rail.

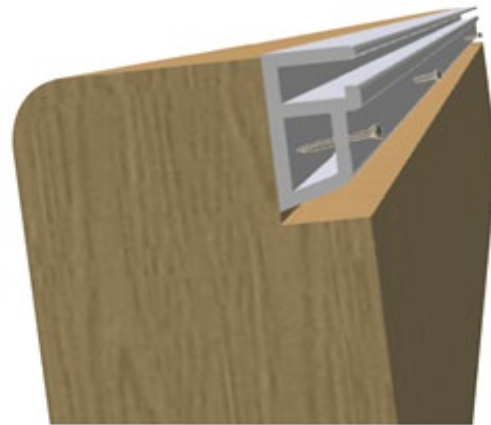

Figure 31 – Installation of the liner locking track

11.2 Drilling for the beam mounting unit

Before fitting the liner, you will need to drill holes to mount the beam on each side of the pool. This beam will support the duckboarding that will cover the area of the pool that contains the automatic cover axle. The beam mounting plate and counter plate are installed after the liner is fitted. Using a 10 mm drill bit, drill blind holes to a depth of about 20 mm.

Position the beam mounting counter plate outside the pool as shown in *Figure 32*. The top of the counter plate should be flush with the top of the pool wall. Check that the part is correctly positioned vertically and mark the location of the four holes on the wood. Using a 10 mm diameter drill bit, make 4 blind holes.

Working from inside the pool, position the counter plate 445 mm from the pool wall, mark the future position of the screws and drill blind holes. The blind holes drilled from inside and outside the pool should meet to form 4 holes.

Repeat this procedure on both sides of the pool.

! The holes drilled should be perfectly horizontal and perpendicular to the pool wall to facilitate subsequent insertion of the beam mounting plate screws.

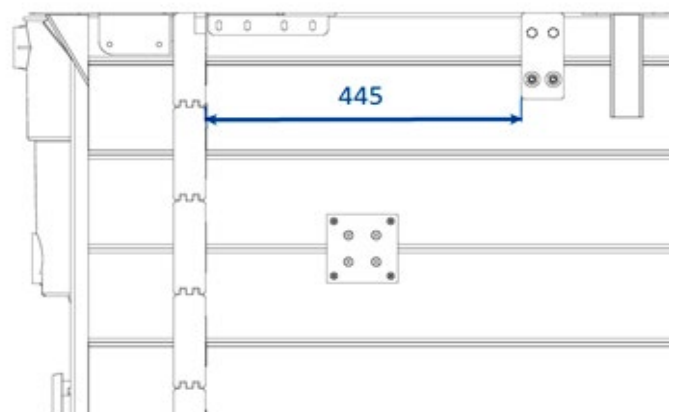

Figure 32 – Position of the beam mounting counter plate

11.3 Applying self-adhesive gaskets

Make sure that the gaskets are correctly positioned and applied. It will be difficult to rectify an omission or mistake after the liner has been fitted. Check that the holes in the various pool fittings (skimmer, throughwall flange, cover bearing mounting unit, etc.) and the holes in the wooden wall are correctly aligned with the holes in the gaskets.

Gaskets should be applied to the following:

- pool fittings (if you did not apply them when installing the part): skimmer and return fitting, throughwall flange and automatic cover axle bearing mounting unit;
- the wooden wall: over the holes drilled to attach the two beam mounting plates and over holes drilled to fasten the ladder (*Paragraph 10.2, page 42*)

11.4 Fitting the underlay

Before spreading the underlay over the concrete, make sure that the surface of the concrete is smooth, flat and clean.

The underlay is precut to the pool dimensions, no trimming will be necessary. Make sure that the underlay completely covers the bitumous strips. Smooth out crease as much as possible before installing the liner.

11.5 Fitting the liner

! Before fitting the waterproofing membrane (liner), make sure that the surfaces are free of splinters or any other surface defects that could damage the liner.

! Ensure that all the gaskets have been correctly applied (*Paragraph 11.3, page 44*).

! The ideal temperature for fitting a liner is between 18 and 25°C.

Put the liner pack in the pool (take care, the liner is very heavy). Remove the liner and unfold it across the pool width (see *Figure 34*) then down the length. Before starting to actually fit the liner, allow the liner to rest for a while at ambient temperature (between 18 and 25°C) so that it becomes more supple and easier to fit.

Climb barefoot into the pool, check that the corners of the liner wall are properly aligned with the corners of the pool structure. It is important to spread the liner out properly. Push the liner beading into the liner locking track in the corners and then continue along the pool walls. Use half clothes pegs to block the liner in position as you proceed (not provided), particularly in the corners (*Figure 33*).

The liner is deliberately manufactured to be 1.5% smaller than the pool structure dimensions, this is to avoid the appearance of creases or folds. It is therefore normal for the liner to be under tension when installed.



Figure 33 – Blocking the liner in position using half clothes pegs



Figure 34 – Unfolding the liner

- ❗ Check that the liner is correctly positioned (no excessive stress loading, no creases on the pool floor or walls).
- ❗ Should the liner need to be repositioned while fitting, never pull it along the track. Release the liner and reposition it to avoid the risk of tearing

If there are creases in the pool floor, smooth them out as much as possible before beginning to fill the pool with water. Check that the liner is correctly engaged in the track, particularly in the corners, before filling the pool with water. Continue to check while the pool is filling. Leave the half pegs in place until the pool is filled.

Fill the pool with a few cm of water, and smooth out any creases pushing them from the centre of the pool towards the walls. Once the water is deeper than 10 cm, it will no longer be possible to smooth out creases. Once creases have been smoothed out, continue filling the pool until the water is 45 cm deep, that is 20 cm below the bottom of the return fitting.

- ❗ Residual creases in the liner caused by folding it are normal and will disappear over time.

11.6 Underwater light cable ties

In the middle of the pool width, on the cover side, glue two adhesive mounts to the liner (*Figure 35* they should be vertically aligned and 70 cm apart, the top one being glued approximately 3 cm from the top of the pool wall). These ties will be used to hold a tube, diameter 16 mm, through which the underwater light power cable will be run.



Figure 35 – Adhesive mounts to hold the cable ties

11.7 Filling the pool with water

In the case of an in-ground installation, check for leaks before burying the pipes and their connections. Open the various valves to allow water into the circuit. Make sure that there are no leaks at the connection points.

Before starting the pump (which should under no circumstances be allowed to run 'dry') make sure that the pre-filter is filled with water. If necessary, open the prefilter basket and fill it with water along with the Skimmer line in order to facilitate priming of the pump.

Put the 6-way valve to Wash to backwash the filter before putting it into operation in filtration mode. For more information concerning this procedure refer to (*Paragraph 16.1.2, page 69*)

11.8 Installing flanges on plastic pool fittings

Before continuing to fill the pool, install flanges on the following pool fittings in order:

- the return fitting (when the water level is 20 cm below the return fitting)
- the throughwall flange and the automatic cover axle bearing mounting unit (when the water level is 5 cm under the part to which the flange is to be applied)
- the skimmer (when the water level is 5 cm under the skimmer)

Installation of the flanges and their gaskets is described step by step in the following four paragraphs.

TIP: Recommendations apply to the installation of all flanges:

- locate the holes in the pool fitting underneath the liner and mark them with a pen ;
- check that the marks line up with the holes in the corresponding gasket by holding the gasket over them ;
- tighten the various flange screws alternately in order to ensure a leaktight fit ;
- tighten by hand, applying too much torque could split the flange ;
- using a Stanley knife, cut away the liner inside the flange.

! Check for leaks while the pool is filling. The water level in the pool should be as shown in *Figure 49*

If while filling the pool, the liner comes away from the track, stop filling the pool before re-engaging it. Depending on the depth of water in the pool, it may be necessary to partially empty the pool before re-engaging the liner.

11.8.1 Return fitting flange

The procedure to follow for installation of the return fitting flange is illustrated in *Figure 36*:

- locate and mark the four screw housings underneath the liner;
- glue the adhesive gasket to the flange, taking care to ensure that the holes in the gasket line up with the holes in the part ;
- screw the flange onto the body of the return fitting using four countersunk screws 5 × 16, A4 SS (enclosed with the return fitting) ;
- using a Stanley knife, cut away the liner inside the flange ;
- lastly, screw the eyeball-union-trim assembly onto the return fitting body.



Figure 36 – Installing the return fitting flange

11.8.2 Throughwall fitting flange

The procedure to follow for installation of the throughwall fitting flange is illustrated in *Figure 37* (in this figure, the liner is sandwiched between parts 4 and 5) :

- locate the positions of the four throughwall fitting (5) holes underneath the liner and mark them;
- glue the adhesive gasket (4) onto the flange (3), taking care to ensure that the holes in the gasket and the part are correctly aligned ;
- screw the gasket (3) onto the return fitting body (5) using four socket head cap screws, 10 × 40, A4 SS (1) equipped with 4 washers(2). The screws and washers are provided in the bag of screws enclosed with the throughwall fitting ;
- using a Stanley knife, cut away the liner inside the flange.

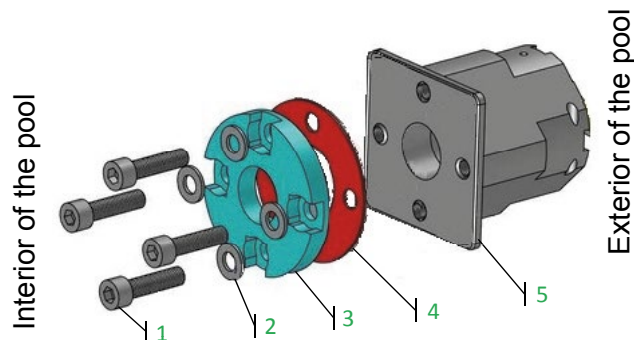

Figure 37 – Mounting the throughwall fitting flange

11.8.3 Bearing mounting unit flange

The procedure to follow for installation of the bearing mounting unit is illustrated in *Figure 38* (in this figure, the liner is sandwiched between parts 4 and 5):

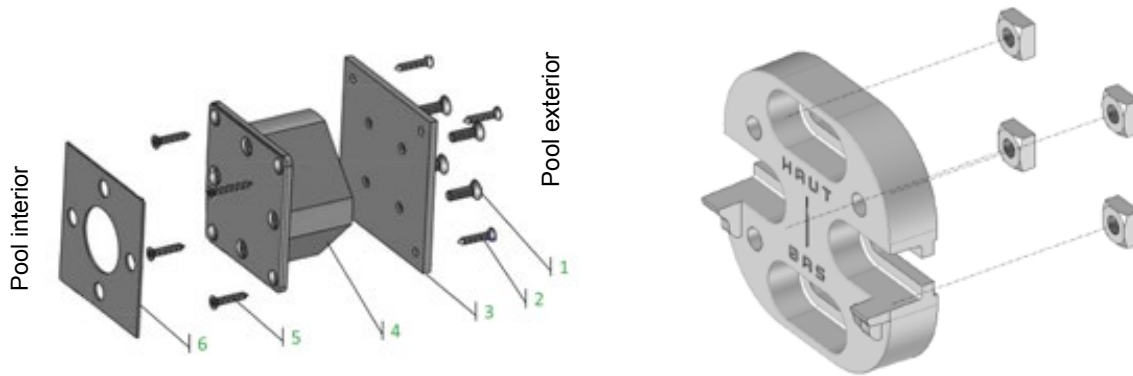

Figure 38 – Assembly of the bearing mounting unit

- Place the 4 square nuts in their housing in the bearing mounting flange.
- locate the positions of the four holes in the bearing (5) underneath the liner and mark them;
- assemble in order: the four socket head cap screws, 10 × 40, A4 SS (1) with four A4 SS washers, diameter 10 mm (2), the bearing mounting unit flange (2), the other four A4 SS washers, diameter 10 mm, then the rubber washers (4). Screw this assembly onto the bearing mounting unit. The screws and washers are provided in the bag of screws enclosed with the bearing mounting unit ;
- adjust the horizontal position of the bearing mounting unit flange before tightening completely, such that the central vertical mark is the same distance from the width wall as the throughwall flange shaft on the motor side.

11.8.4 Skimmer flange

The procedure to follow for installation of the skimmer flange is illustrated in *Figure 39* :

- glue the second gasket onto the inner surface of the skimmer flange ;
- locate the 4 holes in the corners of the skimmer underneath the liner and mark them ;
- screw the flange onto the skimmer through the 4 corner holes. Proceed fastening the skimmer in place using the 18 countersunk screws, 5.5 × 25, A4 SS, tighten the screws alternately (provided in the bag enclosed with the skimmer) ;
- using a Stanley knife, cut away the liner inside the skimmer. Keep the liner cut outs for future repairs.

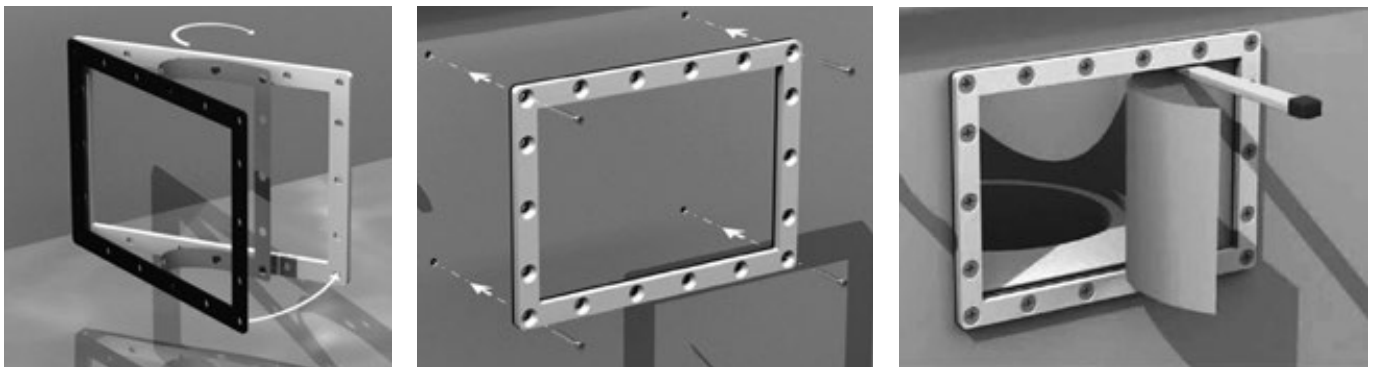

Figure 39 – Mounting the skimmer flange

Next, install the skimmer weir, smooth side facing towards the pool, by pushing the tabs into the notches provided for that purpose in the bottom of the skimmer. The weir should swing freely, however it should not be able to swing out over the pool (the stopper at the top of the skimmer should prevent this). Lastly, clip on the skimmer face plate.

11.9 Installation of the ladder rails

Glue the two remaining gaskets onto the ladder supports (part no. 4 in *Figure 30*).

Install the ladder in the pool, fix it in position by inserting the 4 socket head cap screws, 10 x 80, A4 SS (5) into the two supports (4). Finish assembly started in *paragraph 10.1, page 42* tightening the supports () in their shells (7).

12. ASSEMBLY OF THE AUTOMATIC COVER

12.1 Assembly of the automatic cover axle

12.1.1 Installation of the stainless steel shaft

Working from inside the pool, push the stainless steel shaft into the throughwall flange: the rounded end of the shaft should be outside the pool, while the square end of the shaft should be located inside the pool (*Figure 40*). Push the axle until it is flush with the throughwall flange.

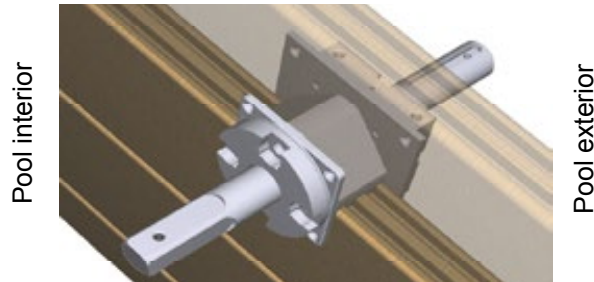

Figure 40 – Mounting the automatic cover shaft

12.1.2 Fitting the axle into the bearing mounting unit

Fit the automatic cover axle into the bearing mounting unit flange (*Figure 41*).

Loosely fasten the axle to the mounting unit using four hex head socket screws 8×35 , A4 SS, and four washers, diameter 8 mm. Do not tighten the screws: you may adjust the position the bearing in the mounting unit to ensure that the cover axle is perfectly level.

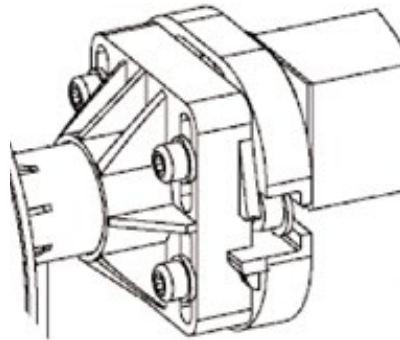

Figure 41 – Fitting the axle into the bearing mounting unit

12.1.3 Fitting the automatic cover shaft into the axle

Push the shaft (previously inserted into the throughwall fitting) into the axle using a mallet. Do not use a hammer. Push it through until the hole in the shaft is facing the hole in the cover axle.

Lock the shaft in position in the axle (*Figure 42*) using a plastic canula, an 8 mm washer and a socket head cap screw 8×65 A4 SS (enclosed with the cover axle).

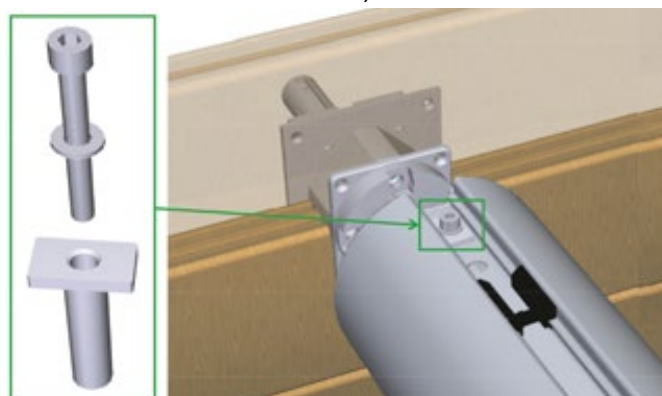

Figure 42 – Locking the shaft in the automatic cover axle

Level the axle: using a spirit level placed on the cover axle, adjust the position of the bearing in its mounting unit as required using the 4 screws fastening the bearing to the bearing support mounting unit flange (see *Figure 41*). Once the axle is perfectly horizontal, lock the four screws in position.

Lastly, remove the protective pin (piece of white plastic) from the end of the shaft located outside the pool.

12.2 Beam and beam flanges

The beam assembly steps are illustrated in *Figure 42*. The screws required for assembly are enclosed in bag Y. In this figure, the wooden wall is located between parts 7 and 8, and the liner is sandwiched between the two rubber gaskets (7).

Glue the remaining self-adhesive gaskets (7) to the beam mounting brackets (5), on the side opposite the threaded rods (the other two gaskets were applied to the wood, before the liner was fitted). Make sure that the holes in the gaskets (7) and the holes in the mounting brackets (5) are properly aligned.

Fasten the mounting plates (5) to the counter plates (8): the plates (5) are located interior of the pool wall with their gaskets in contact with the liner, and the counter plates (8) are placed on the exterior of the pool wall. Use the holes in the bottom made in (Paragraph 10.2, page 42).

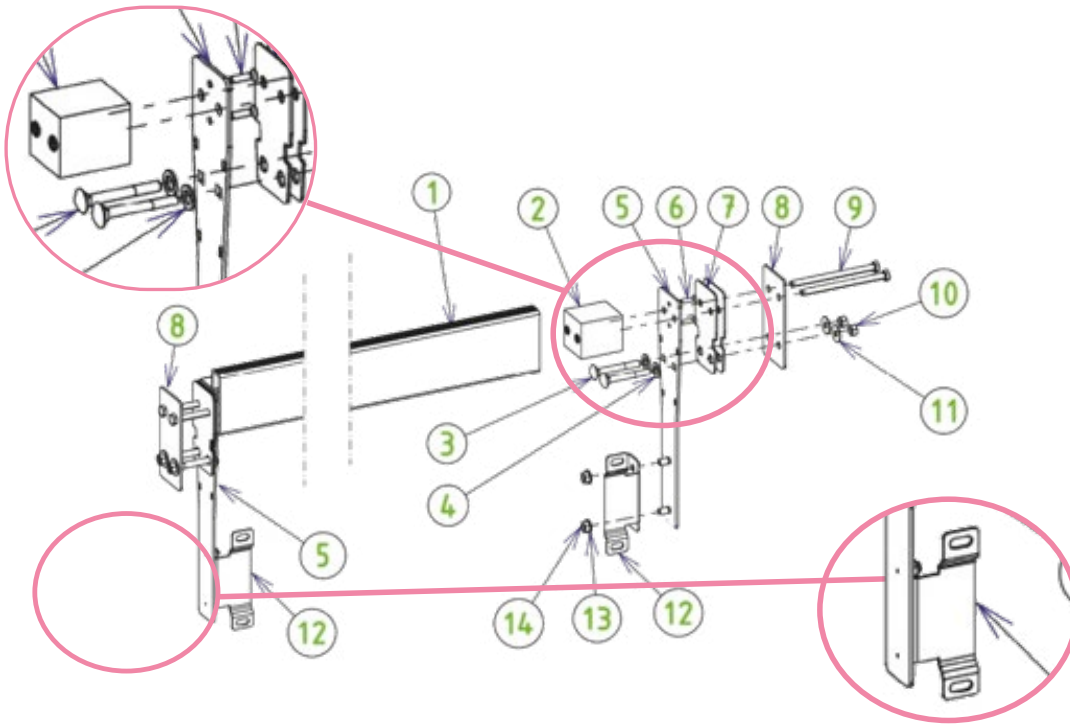

Figure 43 – Assembling and mounting the beam

For the assembly, working from inside the pool, insert four mushroom head square neck bolts, 8 x 70 SS A4 (3) with 8 mm rubber washers (4), then, working from outside the pool, mount washers (11) and 8 mm A4 SS nuts (10).

The holes drilled in the top of the wall in paragraph 10.2 should line up with the remaining 8 mm holes in the mounting plate (5) and counter plates (8).

! the rubber washers (4) are required to ensure that the pool is leaktight.

Fasten the two pit wall mounting brackets (12) to the beam mounting plates (5) using four nuts (14) and four 8 mm diameter A4 SS washers (13). The protruding parts of the pit wall mounting brackets (12) that feature a slot should be located on the side opposite the skimmer and the automatic cover axle (see the zoom focused on the pit wall mounting brackets (12) in *Figure 43*

Insert the polyamide blocks (2) on either side of the beam (1) using a mallet, making sure that the brass inserts on the polyamide blocks are oriented toward the inside of the beam.

Install the beam on the pool facing the beam mounting plates (5), making sure that the holes in the polyamide blocks are aligned with the holes in the plates (5) and counter plates (8). Working from outside the pool, fasten the beam to the outside of the pool using four hex head 8 x 120, A2 SS screws.

12.3 Installing the pit wall and the underwater light

As of the 1st of January 2004, the French pool safety standard NF P 90-308 has required that the portion of the pool in which the cover is installed must be separated from the rest of pool. Installation of the pit wall is therefore mandatory. The pit wall and underwater light assembly steps are illustrated in *Figure 44*. The screws required for assembly are enclosed in bag Y.

Assemble the three pit wall modules (1) using eight hex head 8 × 20 A4 SS screws, and eight 8 mm diameter nuts, place a 8 mm diameter washer on either side of the wall, that is a total of 16 washers. The locations of these screws on the wall are circled in red in *Figure 44*.

Attach three elastic straps (2) to the bottom of the pool wall using three stove head screw 8 x 16, A4 SS , three washers and three 8 mm diameter nuts. The top of the straps will be subsequently fastened to the wooden duckboarding that covers the part of the pool containing the cover.

Drill a hole, diameter 60 mm in the middle of the second module to accommodate the underwater light. Mount the underwater light in this hole, screw the body of the throughwall fitting (5) onto the underwater light (4), then, behind the pit wall screw the nut (6) onto the throughwall fitting body. The underwater light cable should be behind the pit wall.

Fasten the two remaining self-adhesive cable tie mounts (*Figure 35*) behind the pit wall: one, a few cm below the underwater light, and the other directly vertically below it, at the bottom of the pit wall. Engage the cable ties in the mounts to hold the underwater light cable in position. Pass the cable through the 16 mm diameter PVC tube and fix this tube in position using the two cable ties inserted into the cable tie mounts previously glued to the liner (*Paragraph 11.6, page 45*), the cable should protrude from the top of the tube. Leave the cable slack for the time being, you can tension the cable later when the underwater light is fixed in position. During the subsequent assembly of your pool, the underwater light cable will be passed between two duckboarding modules and then under the exterior coping.

Lastly, fasten the pit wall to the brackets (part 12 in *Figure 43*) using four 8 × 16 stove screws (7), four washers and four 8 mm diameter A4 SS nuts.

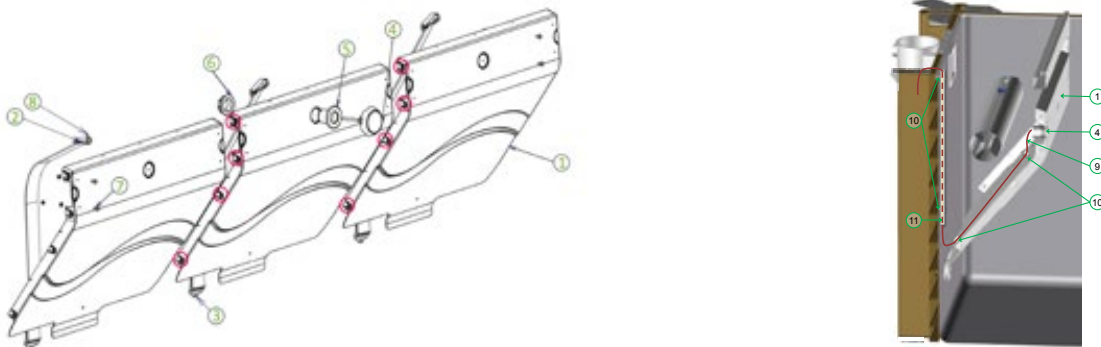

Figure 44 – Installing the pit wall and underwater light

12.4 Automatic cover apron and safety fasteners

12.4.1 Advice prior to installation

Before installing the slat cover apron, make sure that you have the entire cover pre-assembled in modules of 6 slats, the end slat (axle side) holding the straps that fasten the cover apron to the axle, the last two slats (side opposite the axle) that holds the safety straps.

Check that the three U shaped parts that will hold the cover apron fastening straps have been slid into the groove on the axle.

12.4.2 Assembling the slat cover

Assemble the slat modules by floating them on the surface of the water and sliding one into the other. Make sure that the striped under surface of the slats is in contact with the water.

Start sliding at the notch in the plug holding the slat modules at a slat on each module at 150° angle to each other (the slats may be bent during this operation).

Slide them together carefully until they are fully engaged.

! Store the slats in the shade until assembly. If the slats are exposed to sunlight while not in contact with the water, they could heat up and be deformed. Slats deformed by heat will not be covered by the guarantee.

Once the cover apron is assembled, the plugs will prevent the slats sliding from laterally.



Figure 45 – Assembling the slat apron

Fasten the slat on the axle side to the axle as illustrated in *Figure 46*. The U shaped parts can slide freely so that they can be positioned opposite the straps fastened to the cover slat.

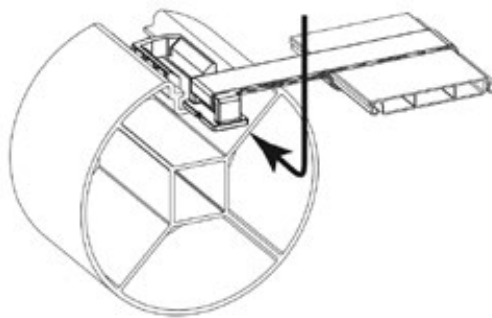

Figure 46 – Slat apron/ axle junction

12.4.3 Installing the cover apron safety fastener

Installation of the safety fasteners is illustrated in *Figure 47*.

The safety straps (8) are pre-installed on the first two slats of the cover apron. Use the mounting brackets(1) as a drilling template and pre-drill the wall at the locations where the cover safety fasteners will be mounted, that is, the wall opposite the axle, exactly opposite the safety straps. Position the mounting brackets such that the marks N are at the water level (*Figure 47*).

Fix the mounting brackets (1) to the wall using round head Phillips screws 5.5 × 50 (2) fitted with 6 mm diameter washers (3), after inserting the gasket (4) between the mounting bracket (1) and the liner.

Clip the decorative trim (7) onto the mounting bracket (1) by pressing down hard, and making sure that the stainless steel bar (6) is lowered. Make sure that the trim is fastened on all the way around.

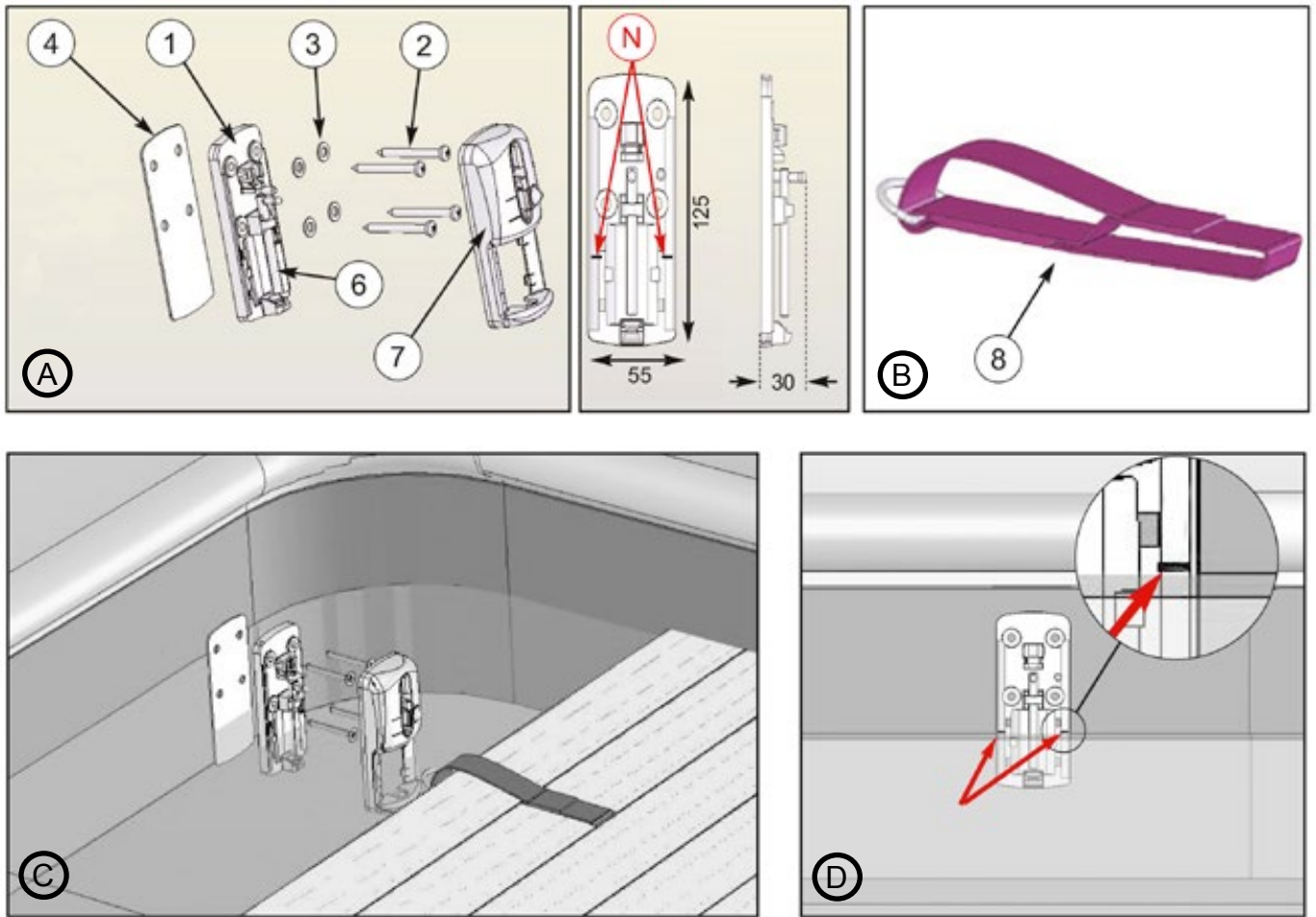

Figure 47 – Mounting the cover fasteners

12.4.4 Securing and releasing the slat cover

To secure the slat cover, roll the cover out over the surface of the water, press the button A, shown in *Figure 48* and slide the bar up, then lower it through the ring on the end of the strap. Lower the sliding bar fully to make sure that the strap is secured.

To release the slat cover, press button A and slide the bar up to release the strap ring.

- ❗ The use of fastening straps is mandatory according to French safety standards.
- ❗ Do not forget to release the straps before rolling the cover up: rolling the cover up before releasing the fasteners could lead to significant damage.

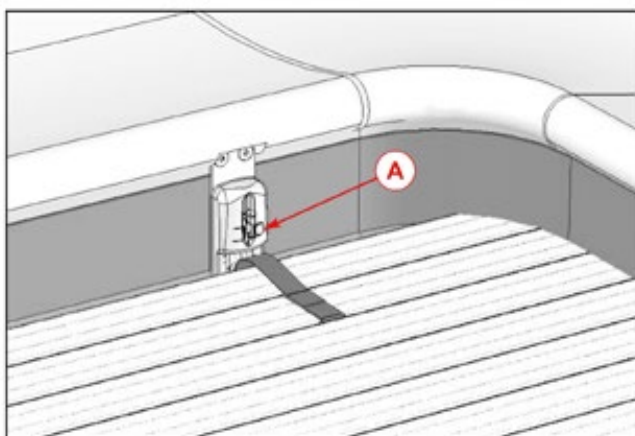

Figure 48 – Securing and releasing the cover apron

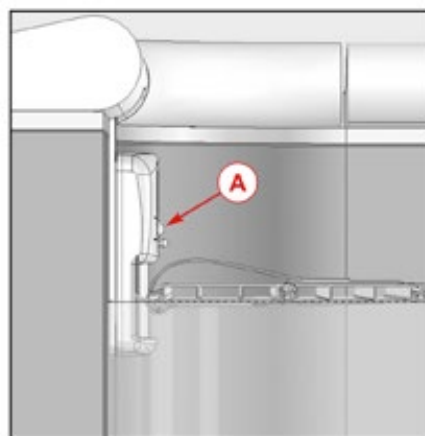

Figure 49 – View from the side

12.5 Water level in the pool for correct operation of the cover

As illustrated in *Figure 50*, the average water depth in the pool (measured from the top of the beam) is 13 cm. The water depth is then 1.2 m with respect to the pool floor.

- ! For the automatic cover to operate correctly, make sure that the water level is always between 10.5 cm and 16 cm above the top of the beam. Failure to do so could lead to serious damage to the cover while it is being rolled up or rolled out.

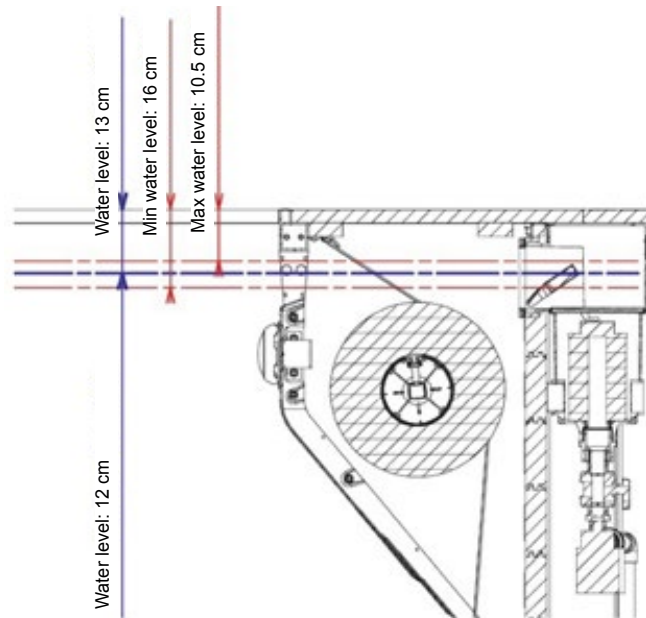

Figure 50 – Water level in the pool

- ! To prevent the water level from rising above the maximum allowed water level, punch out the disk at the back of the skimmer. This hole will act as an overflow for the pool. You may attach a PVC tube to channel overflow water so that it does not run down the skimmer and the pool wall.

13. INSTALLATION OF THE COPING AND FINISHING ELEMENTS

13.1 Coping

Note the layout of various pool coping modules in *Figure 51*. Orient them so that the grooved surface is facing up around the periphery of the pool. Allow a 25 mm overhang over the inside the pool (measured from the pool wall). Take the time necessary to ensure that the coping modules are correctly aligned and that the overlap is even. The gap between the interior and exterior modules will vary between 2 and 5 mm.

Working from underneath, fasten the coping to the metal fittings mounted in the corners and on the supporting braces and to the metal plates mounted on the wooden brackets using 4 torx safety screws 6 × 20, A2 SS (bag G) per element, inserted through the centre of the slots, that is a total of 168 screws.

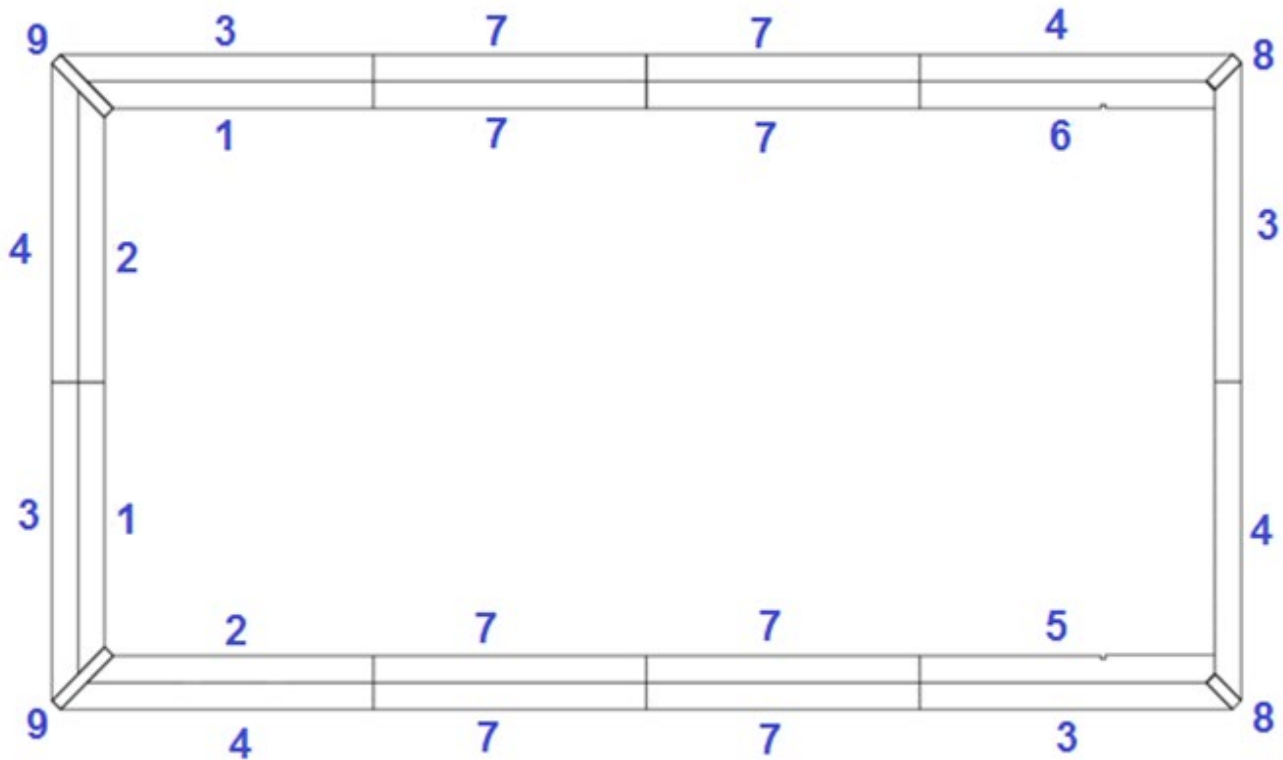

REF	Description	Dimensions (mm)	Type	Qty
n°1	Coping	1570 × 145 × 28	Left interior	2
n°2	Coping	1570 × 145 × 28	Right interior	2
n°3	Coping	1716 × 145 × 28	Left exterior	4
n°4	Coping	1716 × 145 × 28	Right exterior	4
n°5	Coping	1621 × 145 × 28	Left interior	1
n°6	Coping	1621 × 145 × 28	Right interior	1
n°7	Coping	1500 × 145 × 28	Interior and exterior	8
n°8	Bevelled cleat	206 × 70 × 28	Corner	2
n°9	Bevelled cleat	412 × 70 × 28	Corner	2

Figure 51 – Layout of the coping modules

13.2 Assembling and installing the duckboarding

Assemble the 5 duckboarding modules as illustrated in *Figure 52*. Leave a gap of about 2 mm between neighbouring coping modules. The modules should rest on the pool wall that holds the skimmer and the beam. To do this, use:

- 10 cleats, length 585 mm ;
- 20 cleats, length 600 mm ;
- 80 countersunk screws 5 × 40 SS A4 threaded over 25 mm (bag Z).

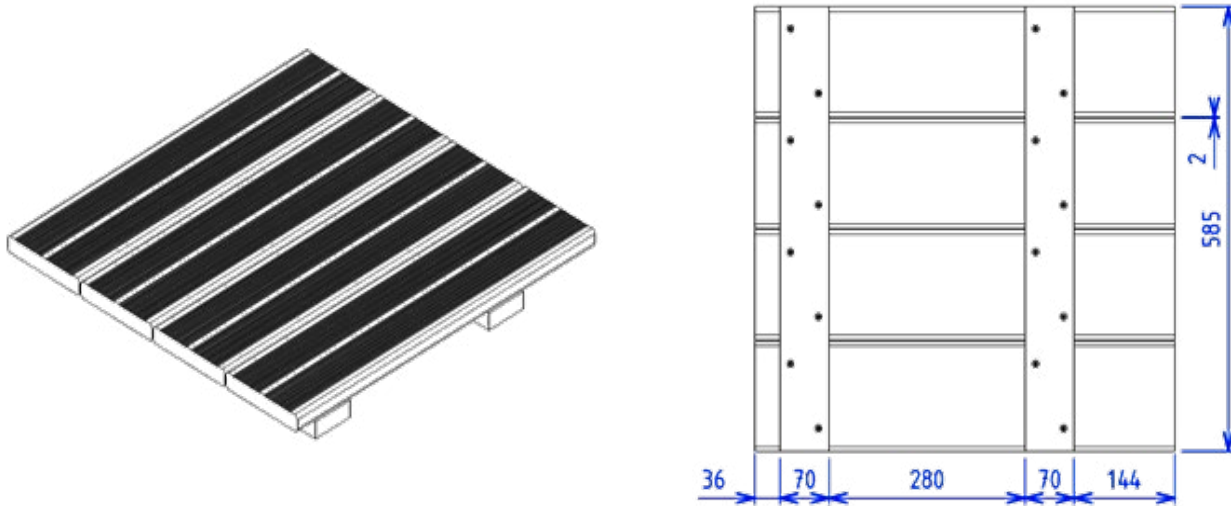

Figure 52 – Assembling the duckboarding

Put the duckboarding in position (*Figure 53*). Fasten the loops on the elastic straps attached to the pit wall to the underneath of the cleats at a distance of 105 mm from the end of duckboarding modules no. 1 and no. 5 and to the middle of duckboarding module no.3. For this, use three hinge screws 6 × 30 SS A2 (bag Y). The straps should be parallel to the wall constituting the length of the pool.

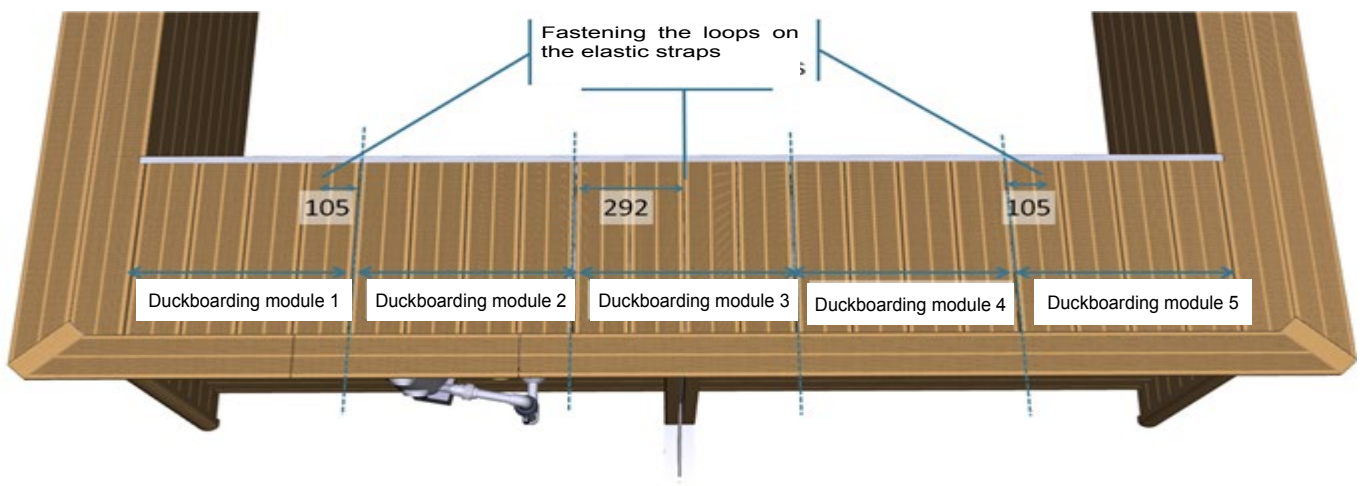

Figure 53 – Fastening the elastic straps underneath the duckboarding

13.3 Ladder hand rail

Drill vertical holes in the coping over the wooden steps at the locations of the 8 holes in the left-hand and right-hand handrail mounting brackets that are also being used to hold the wooden ladder in position *Figure 17, (Paragraph 6.6, page 26)*

Next, fasten the two ladder handrails in position using eight mushroom head screws 8 × 50, A2 SS, fitted with eight washers and eight nuts, diameter 8 mm (bag B). The washer and nut of each screw should be located underneath the coping.

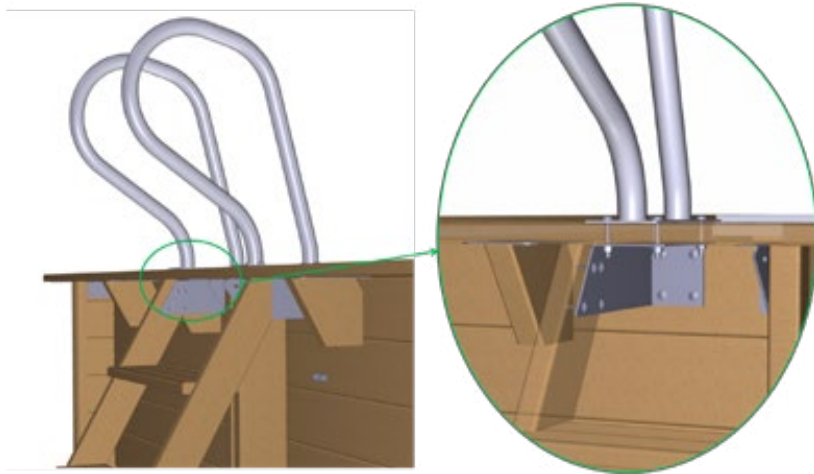

Figure 54 – Mounting the ladder hand rails

13.4 Wiring

A wiring diagram for XL URBAN POOLS is provided in *Figure 55*. The components indicated are necessary for XL URBAN POOLS to be wired in according to the French safety standard NF C15-100. The pump transformer and the electrical panel should be installed in a place protected against sun and bad weather.

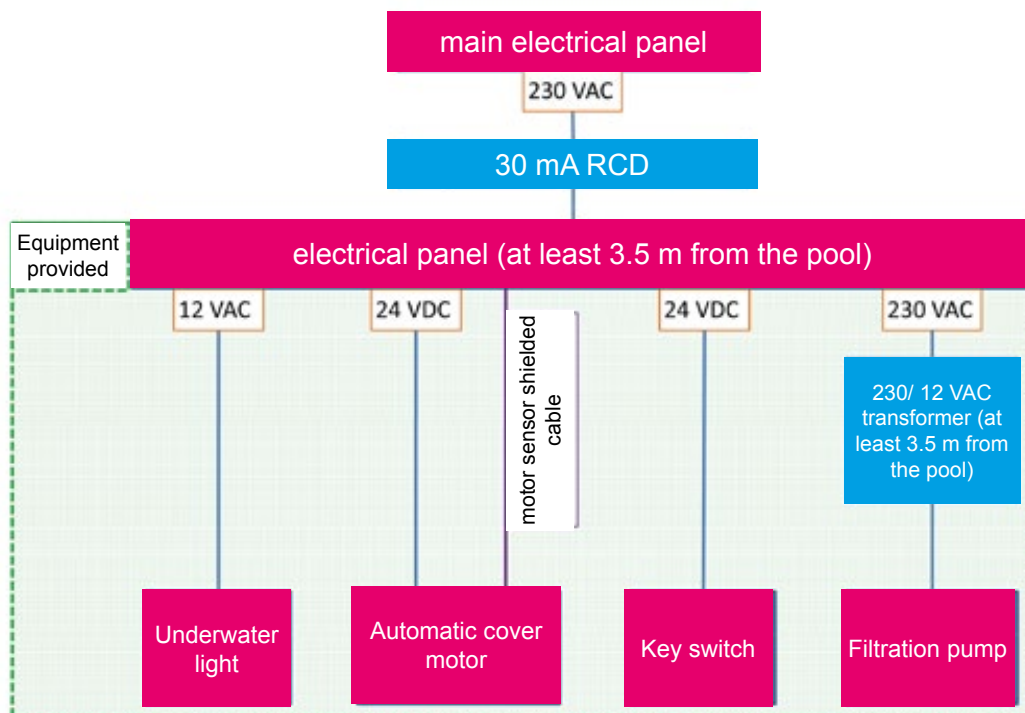

Figure 55 – Urban pool wiring diagram

13.5 Automatic cover motor

13.5.1 Safety advice concerning the motor

The URBAN POOL motor is intended for use with URBAN POOL automatic covers. The motor only runs with the electrical panel provided. Operation of the cover without the electrical panel is dangerous and not advised.

The automatic nature of the closing and opening of the cover in no way dispenses the user from exercising proper vigilance while the cover is moving. Should you encounter the slightest problem while rolling the cover out or up, stop the cover (move the key switch to position 0). The key switch should be installed in a location that allows a clear view of the whole pool.

Do not leave the key in the key switch: Store it out of the reach of children each time after you operate the cover (to remove the key, turn the key to position 0).

13.5.2 Assembly of the automatic cover motor

Orient the stainless steel shaft that you previously inserted into the throughwall fitting such that the groove is facing upwards. Slide the water slinger (o-ring) onto the shaft.

Place the motor pin in the groove in the shaft, then install the motor by lining the pin up with the groove. Push it in fully. If you meet resistance, check that the motor pin is correctly positioned.

Put the U-shaped pin in position, making sure that it comes out through the bottom of the lower mounting flange.

13.6 Electrical panel: mounting and wiring

The electrical panel terminals to which you should connect the various components are illustrated in *Figure 56*.

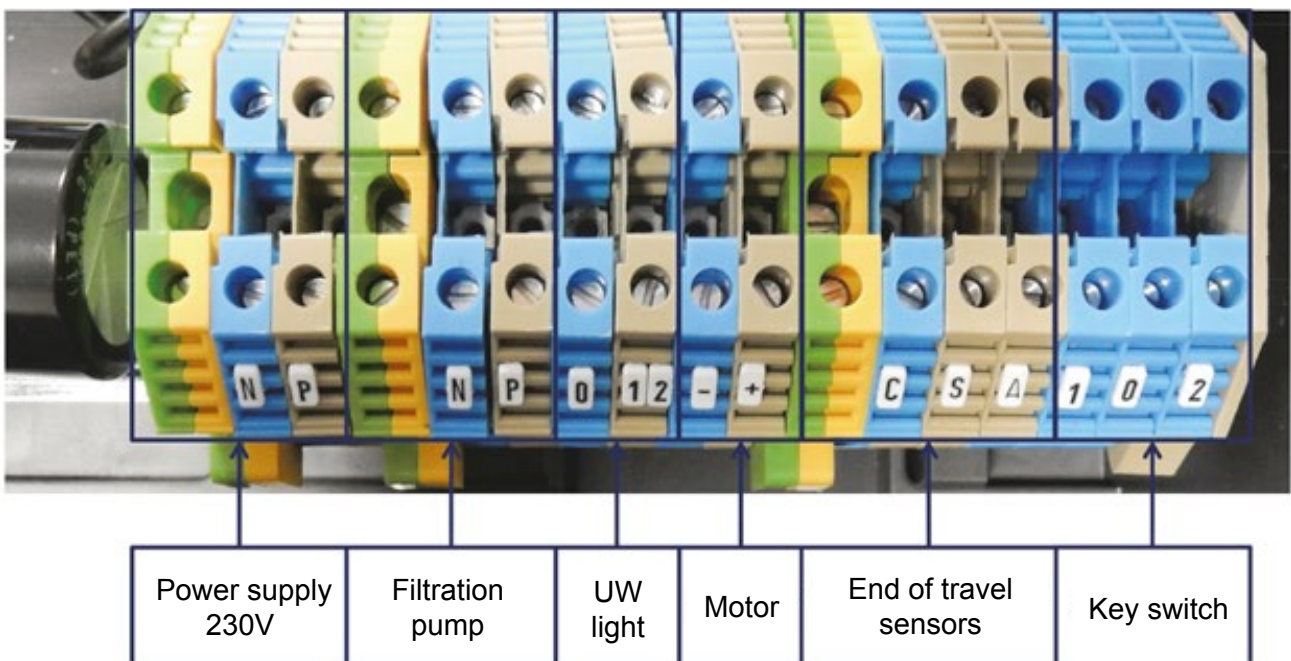
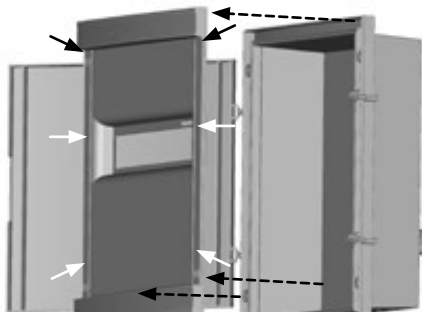

Figure 56 – XL URBAN POOL electrical panel

! The electrical panel must be installed in accordance with the rules of the art and the standards in effect in the country of installation:

- according to the French standard NF C15-100, a 30 mA RCD must be installed at the head of the line;
- prior to any intervention requiring removal of the front face, make sure that power to the electrical panel has been cut;
- if a fuse needs to be replaced, use a fuse with the same rating.

13.6.1 Mounting the electrical panel on the wall



- Loosen the 6 plastic screws and remove the front plate and remove the front panel;

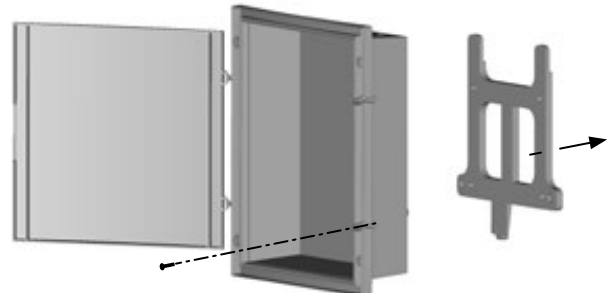

- remove the screw from the mounting bracket at the back of the electrical panel and use the bracket as a drilling template;

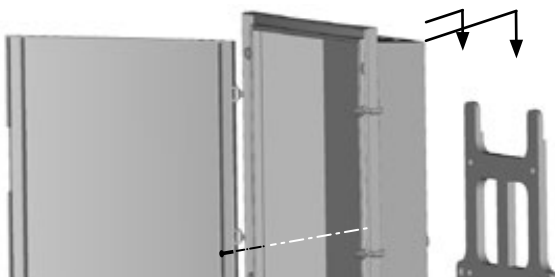

- Fix the bracket to the wall, hang the panel on the bracket and replace the screw to fasten the panel in position;

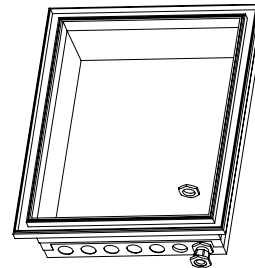

- install the cable glands to allow passage of the cable (one cable per cable gland) and carry out the connections. Tighten the cable gland around the cable to ensure a leaktightness of the connections. Once wiring is complete, replace the front panel.

The electrical panel door is reversible. To reverse the opening, start by removing the door, the hinges and the locking mechanism, swap the position of the hinges and the locking mechanism then clip the door into its hinges.

13.6.2 Electrical panel power supply

Connect the 230 V power supply to the N (neutral) and P (phase (live)) terminals at the bottom of the electrical panel and the earth to the yellow and green terminal to the left of the connection terminals (see [Figure 56](#)).

13.6.3 Connecting the filtration pump

Connect the two wires protruding from the pump transformer to the series of N and p terminals second from the left in the electrical panel (see [Figure 56](#)).

13.6.4 Connecting the underwater light

Connect the two wires from the underwater light to terminals 0 and 12 in the electrical panel (see [Figure 56](#)). The wiring polarity is unimportant.

13.6.5 Connecting the motor

Connect the + and - terminals in the electrical panel (see [Figure 56](#)) to the + terminal (brown wire) and - terminal (blue wire) using the cable connected to the motor. This unshielded cable comprises two wires with a cross section of 2.5 mm².

- ! The cable should not be taut: allow enough slack to create a loop facing down, this will channel away any drops of water.



- ! The brown wire must be connected to the + terminal, and the blue wire must be connected to the - terminal. A wiring error will reverse rotation of the motor and cause serious damage to the automatic cover.

To extend the cable (if the electrical panel is located more than 3.5 m from the pool), a cable with the same specifications must be used, and wires must be connected via a watertight junction box or using leaktight heat shrink sheaths (one per wire and one for cable itself). The maximum length of the cable between the motor and the electrical panel is 25 m.

13.6.6 Connecting the end of travel sensors

Using the shielded cable that comprises three wires with a cross section of 1 mm² numbered 1 to 3, connect terminals C (Common), S (Signal) and A (Alimentation (power supply)) in the electrical panel (see [Figure 56](#)) to the motor sensor. To do this, connect:

- wire no.1 to terminal A ;
- wire no.2 to terminal S ;
- wire no.3 to terminal C.

The metal braid on the shielded cable should be connected to the earth terminal in the electrical panel (see [Figure 56](#)).

- ! Wire no.1 must be connected to terminal A, wire no. 2 to terminal S and wire no. 3 to terminal C, failure to wire in the end of travel sensor correctly could result in irreversible damage to the motor sensor..

13.6.7 Connecting the key switch

The location of the key switch must allow an uninterrupted view of the whole pool to ensure that no-one is in the pool while operating the cover. The key switch terminals are numbered 0 to 2 in [Figure 57](#)

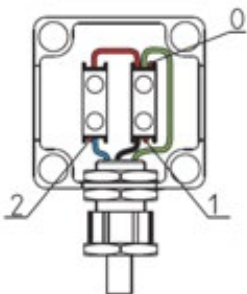

Figure 57 – Key switch

Carry out the following connections using a 3 x 1.5 mm² cable:







- terminal 0 of the electrical panel to the top right of the key switch (terminal 0 – common) ;
- terminal 1 of the electrical panel to the bottom right of the key switch (terminal 1 – open) ;
- terminal 2 of the electrical panel to the bottom left of the key switch (terminal 2 – close),

13.7 Adjusting the ends of travel

This step is carried out using the control pad in the electrical panel. The control pad comprises 3 buttons and 5 LEDs, their functions are described in the following table.

For the first two LEDs, flashing indicates that learning is underway, a steady light indicates that the positions need to be learned (first two LEDs are lit).

If the 5th LED is lit up, this means that there is a motor sensor signal fault.

						
ends of travel	anti-tear	not used	motor sensor signal	validation of the closed position	validation of the open position	validation of the step carried out

For the initial installation, or when modifying the end of travel settings, start with an initialisation as described in the following three steps:

If the 5 LEDs are off, press the open lock and closed lock keys simultaneously and hold them down for 5 seconds, the 5 LEDs start flashing.

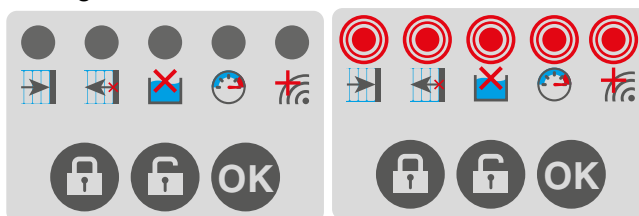

While the 5 LEDs are flashing, press the OK key for 1 second. The two LEDs on the left-hand side light up.

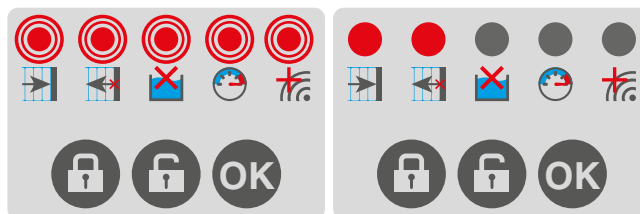

To set the ends of travel and the anti-tear, do the following:

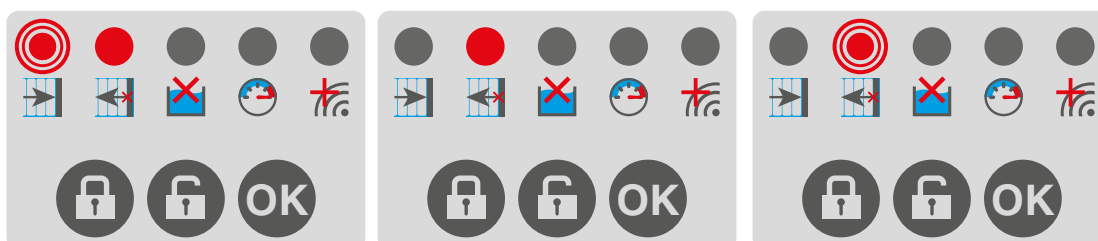

- turn the key to roll out the slat cover until it reaches the side opposite the axle ;
- validate the pool closed position by pressing the closed lock key ;
- the first LED flashes, the second LED is lit steadily.
- turn the key to roll the cover up over the axle until the first slat is just below the surface of the water ;
- validate the pool closed position by pressing the open lock key ;
- the first LED flashes, the second LED is lit steadily.
- turn the key and hold it in the close position until the motor stops ;
- next, turn the key briefly to the open position; the slatted cover rolls up around the axle and the 2nd LED flashes ;
- the 2nd LED goes out 20 seconds after the cover is rolled up.

! For safety reasons, contact must be maintained while rolling the cover out over the pool: turn the key to unroll position (pool side), and hold the key in position until the cover stops moving at the previously set closed position.

Contact does not need to be maintained to roll the cover up: to roll the cover up around the axle, turn the key briefly to the open position, the cover will roll up until it reaches the previously set open position.

The following could cause deletion of the end of travel settings:

- power cut while opening or closing the cover ;
- power cut while the cover is partially open or closed.

Should this occur, reprogram the ends of travel as described previously.

14. COVER PIT FOR URBAN POOLS

If you intend to install this pool in-ground (fully or at a depth greater than 62 cm), the motor must be housed in a dry pit mounted beside the automatic cover.

The dry pit is a compartment that is mounted on the wooden structure of the URBAN POOL, to house the automatic cover motor. It is made of wood that looks identical to that of the pool structure to ensure seamless integration.

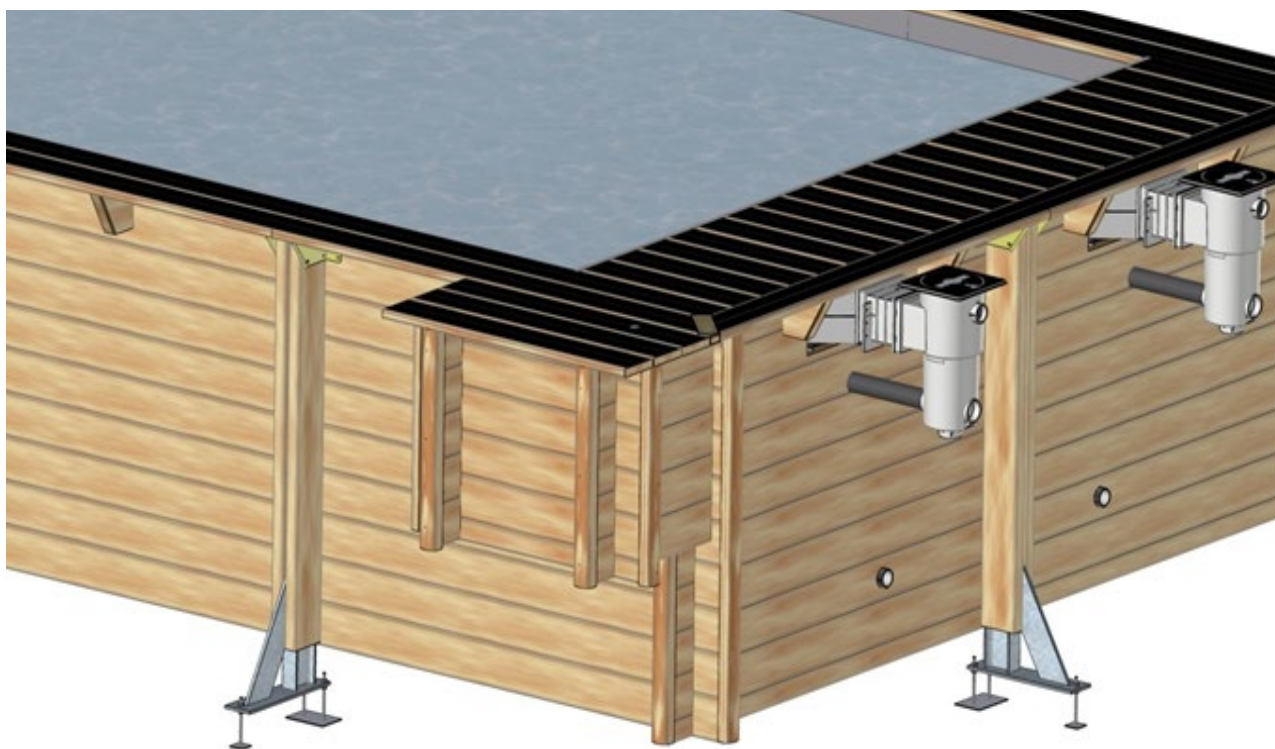

Figure 58 – Position of the cover pit on the pool

Installation of the cover pit is mandatory if your URBAN POOL is sunk more than 62 cm into the ground to ensure that the motor remains accessible.

! If you intend to defer instalment of the cover pit, store your package properly without opening it, in a dry well-ventilated area, or failing this, in an area sheltered from the sun and inclement weather. The aim is to prevent any deformation of the wooden elements that could hinder assembly. Abnormal deformation of the wood could only be the result of failure to respect storage conditions after delivery.

! Whether installed in-ground or partially in-ground, the same precautions should be applied to the wooden structure of the cover pit as to the wooden structure of the URBAN POOL itself:

- Apply a layer of geotextile to those portions of the outer wall that will be under ground ;
- Paint any cut edges with an anti-rot product.

14.1 Nomenclature

14.1.1 Hardware

REF	Description	Qty
a	Long hinge 60 x 40 x 1.5 SS 304L	2
b	Lock with key and cam	1
f	Lock strike plate, SS 304L	1
f	Hinge screw 6 x 30 SS A2	2
c	Countersunk screw 5 x 40 torx threaded over 25 mm SS A2	12
d	Countersunk screw 5 x 80 torx threaded over 50 mm SS A2	12
e	Countersunk screw 4 x 35 SS A2	12
g	Tack 2.8 x 60	12

14.1.2 Wooden elements

REF	Description	Qty
1	Wall slat 626 x 145 x 45 mm, cover pit	8
2	Wall slat 626 x 137 x 45 mm, female, cover pit	2
3	Wall slat 905 x 75 x 45 mm, cover pit	1
4	Wall slat 905 x 145 x 45 mm, cover pit	4
5	Wall slat 905 x 70 x 45 mm, cover pit	1
6	Pine, finishing trim 685 x 70 x 45 mm	4
7	Double pine coping 975 x 145 x 28 mm	2
8	Double pine coping 975 x 145 x 28 mm, lock	1
9	Hatch cleat	2
10	Cleat 45 x 45 mm	1
11	Double pine coping 238 x 70 x 28 mm, cover pit corner	1

14.2 Cover pit exploded view

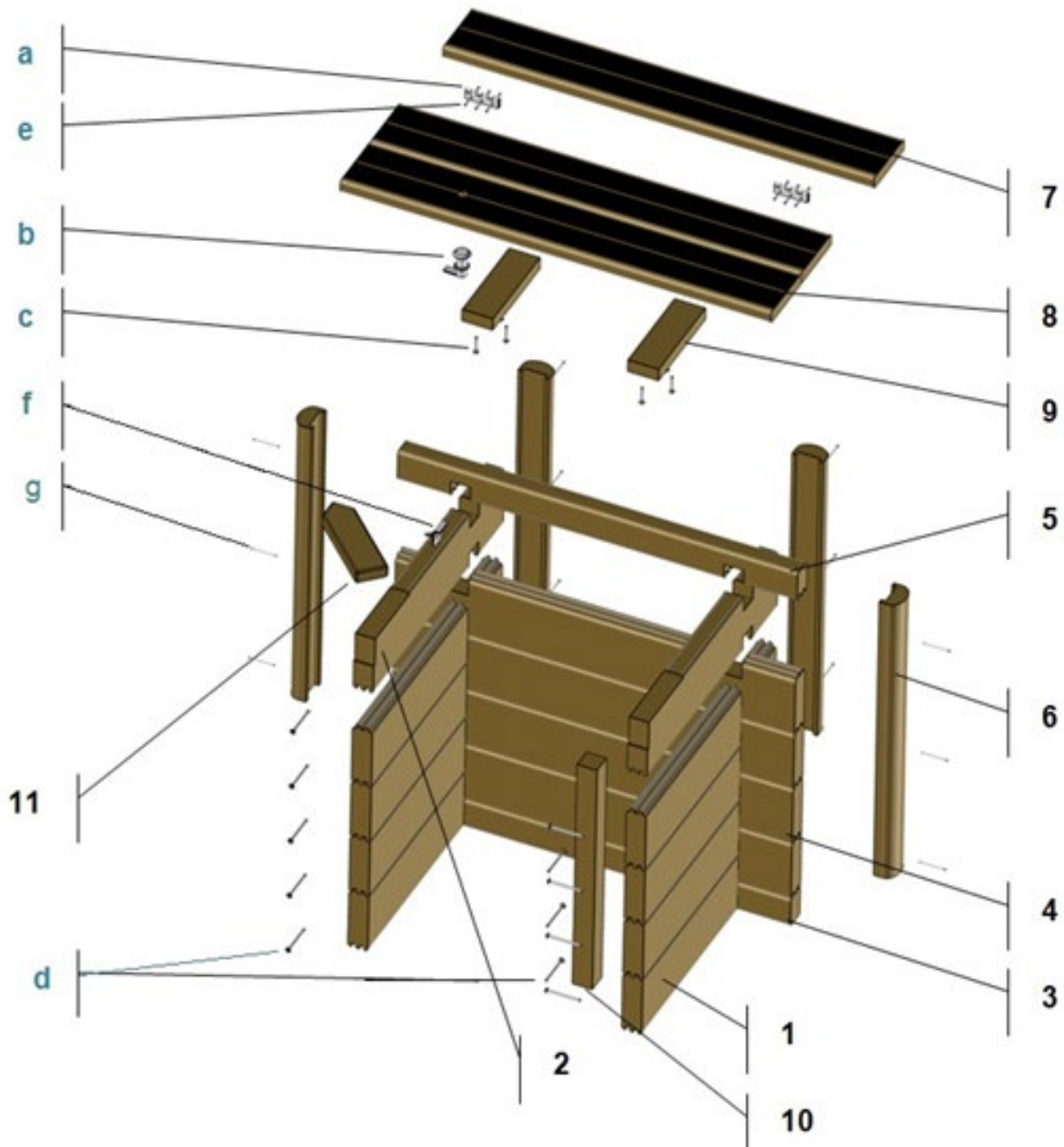

Figure 59 – Cover pit exploded view

14.3 Assembly

Time required: 1 HOUR WITH 2 PEOPLE

Tools required:

- Martyr slat (use the one delivered with the pool structure) ;
- Mallet ;
- Measuring tape ;
- Electric screw driver ;
- Cross-head bit and torx bit no. 30 and 25 ;
- Drill bits 2, 3 and 4 for pre-drilling screw positions ;
- Wrench.

The cover pit should be put together after the pool wooden structure has been fully assembled.

14.3.1 Assembling the walls

Start assembly from the bottom of the structure, and proceed upwards, row of slats by row of slats. The wall slats fit together by means of a double groove (female) and tongue (male) along the length of the slats and notches at either end (*Figure 60*). The tongues should always face upwards and the grooves should face down.

Place the two 626 cm slats (1) that will constitute the cover pit widths on the ground against the pool in the exact location where the cover pit should be installed (*Figure 61*), then slot the 905 cm slats (3) that will constitute the lengths into position. Build up the rows checking regularly that the corners are square and that the walls are level. Make sure that the slats are fully engaged in each other. Finish with slats 2 and 5.

To finish, fasten the 45 × 45 mm cleat (part no.10 in *Figure 59*) in position using 4 countersunk torx screws 5 × 80 threaded over 50 mm (d). This cleat should be flush with the end of the cover pit slats.

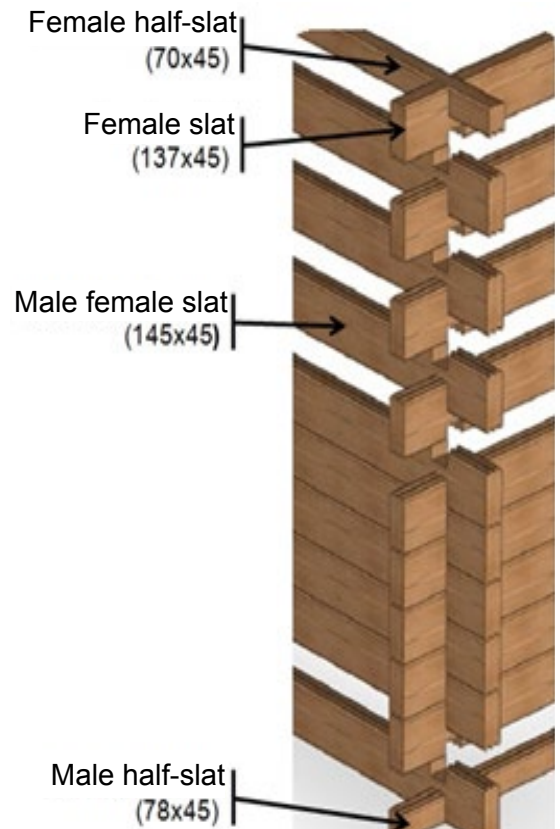

Figure 60 – Slotting together the wooden slats

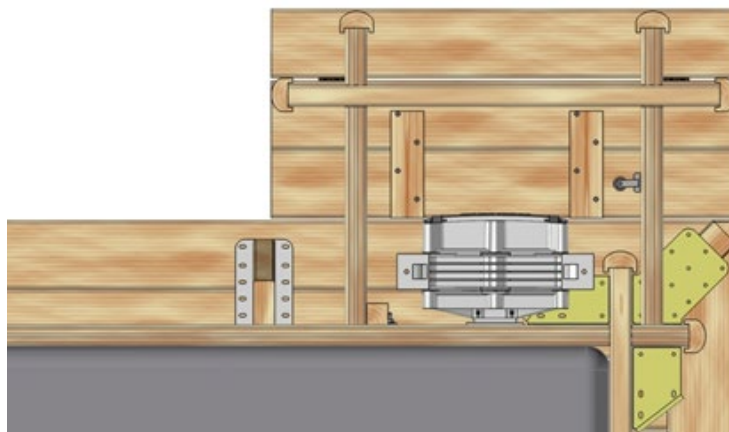

Figure 61 – View from below– Position of the cover pit

14.3.2 Mounting the finishing trim on the ends of the walls

Paint the ends of the slats with a sealant to prevent cracking before mounting the finishing trim.

Fasten a finishing trim to the end of each wall. To do this, use three dome head nails 2,8 x 60 (g) One at the top, one at the bottom. Make sure that the nails are centred in the wall slat to avoid splitting them.

 The trim should not protrude above the top of the wall.

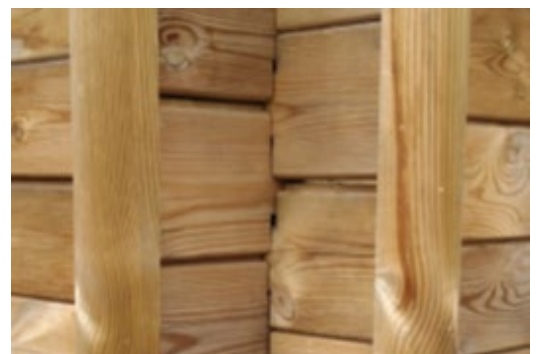

Figure 62 – Slotting together of the wooden slats

14.3.3 Swapping out the pool corner cleat

The corner part delivered with the wooden pack of your Urban pool is rectangular. After installing the coping on your cover pit, a triangular space will be left empty. To avoid this situation, swap this part for the part with the pointed end enclosed with the cover pit (part no. 11 in [Figure 59](#)).

Working from underneath, fasten the cleat to the corner bracket using a hinge screw 6 × 20 that you recovered for cleat ([Figure 63](#)).



Figure 63 – Cleat to be swapped out

14.3.4 Fastening the cover pit to the pool

The cover pit is fastened to the URBAN POOL structure at two points:

- Fasten the cleat (part no.10 in [Figure 59](#)) to the pool wooden slats using three countersunk Torx screws 5 × 80 threaded over 50 mm (d);
- to the cover pit slats, through the pool structure slats (see [Figure 64](#)) using 5 countersunk Torx screws 5 × 80 threaded over 50 mm (d); Avoid placing the screws close to the edge of the cover pit slats to avoid splitting the wood.



Figure 64 – Fastening the cover pit to the pool

14.3.5 Fastening the hinges to the cover pit

To allow access to the inside of the cover pit, it is equipped with a hatch mounted on two hinges. It is also fitted with a lock to prevent it from being opened.

Using 3 countersunk screws 4 × 35 per hinge, mount the two hinges on the edge of a duckboarding coping module 97.5 cm long (part no.7 in [Figure 59](#)) at the positions indicated in [Figure 66](#).

Follow the hinge mounting instructions provided in [Figure 65](#).



At least half of the hinge axis must be above the top surface of the coping module

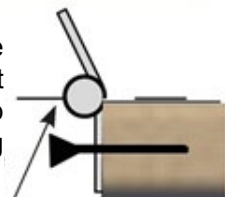

Figure 65 – Mounting the hinges

14.3.6 Duckboarding assembly

Join the two remaining 97.5 cm coping modules (one of which has been drilled to hold the lock) together with cleats attached from below. Use two countersunk 5 × 40 torx screws, threaded over 25 mm per cleat and per slat, that is a total of 8 screws (c), paying attention to the location of the lock housing and the dimensions shown in [Figure 66](#), and leaving a gap of 2 mm between the two copings.

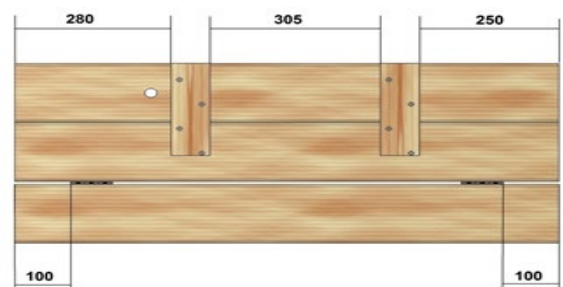



Figure 66 – Assembly of the duckboarding

14.3.7 Positioning the coping on the cover pit

Position the duckboarding on top of the cover pit leaving a 2 mm gap between the hatch and the pool coping.

Fasten the duckboarding to the cover pit slats from underneath using 4 countersunk 5 × 40 torx screws threaded over 25 mm (c).

 To avoid injury to peoples' feet, make sure that the screws do not protrude above the coping.

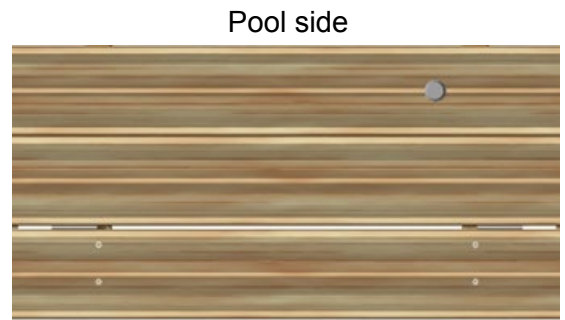

Figure 67 – Mounting the duckboarding

Fasten the hinges to the free section of the duckboarding using 6 countersunk screws 4 × 35 (e).

14.3.8 Assembling the lock

The hatch locking mechanism is comprised of a lock barrel, a lock cam to fitted to the end of the lock barrel, and a strike plate to be fitted to the cover pit slat machined to hold the lock (part no. 2 in *Figure 59*).

- Follow these steps to mount the cover pit lock ;
- unscrew the nut and the hex screw of the lock barrel ;
- thread the o-ring onto the barrel ;
- insert the lock barrel through the 20 mm hole provided for this purpose at the end of the coping and push it in fully ;
- working from above the coping, screw the hex nut back into position and tighten ;
- position the lock cam at the end of the barrel. It should be oriented toward the cover pit lock slat when the lock is closed. Screw the hex screw back into position and tighten ;
- mount the strike plate using 2 hinge screws 6 × 30, on the vertical face of the lock slat, oriented toward the lock such that the cam is loaded under the lip of the strike plate when the cover pit is locked.



Figure 68 – Assembling the lock

15. SAFETY

For your safety, and that of you children, you should read the safety instructions carefully and comply with all points. Safe use of an URBAN POOL requires adherence to all safety instructions set out in this assembly, maintenance and operation manual.

15.1 Electrical supply and filtration pump safety

The electrical panel power line must be protected at the head of the line by a 30mA RCD. Make sure that your installation complies with the NF C15 100 standard. If the filtration pump begins to leak, switch it off immediately. Check the pump cable regularly for damage. For electrical safety reasons, the pump cable cannot be replaced. Do not expose the pump to temperatures below 0°C. To avoid damage to the motor, never let the pump run dry. Never pull the pump by its cable.

15.2 Safety of all users

! For the safety of all, always keep the cover closed while the pool is unsupervised, even for a short time, and while the pool is not in use and secure the cover to the safety fasteners at the end of the pool.

Young children and people who do not know how to swim should wear a floatation device (vest or arm bands) when in the pool. Do not allow children who do not know how to swim and are unaccompanied access to the pool without a swim vest or arm bands. Without these precautions, access to the pool should be strictly prohibited. Before entering the pool, each person should wet the back of their neck, their arms and legs to avoid thermal shock.

Ladders and steps should only be used to enter and leave the pool. They should not be used for any other purpose as this could be dangerous. Step surveillance up when there are more people in the pool. Keep a pole or life-ring close to pool in case of a problem. Jumping should be prohibited. The same applies to running and boisterous play.

Attach the safety plate (*Figure 69*) to the wall of the pool using 4 countersunk screws 4 × 25 (bag K).

Safety instructions that apply to all users are as follows:

- do not dive ;
- do not walk or stand on the coping ;
- do not leave the pool empty without protection.



Figure 69 – Safety plate

! Accidents don't just happen to other people, be ready to react! Notably:

- memorise first aid numbers and display them near the pool. 112 in the European Union. Also, display the number of the nearest anti-poison centre at the pool site ;
- learn first aid so that you can provide assistance in the event of an accident.

Keep the water clean and healthy while the pool is in use. Prevent access to the pool while filtration system is out of order and during maintenance.

15.3 Safety of children

Your URBAN POOL is suitable for users aged 3 years and older. The risk is at its greatest when children are less than 5 years old. Make sure that there is access to a phone (landline or mobile) close to the pool to avoid leaving children unattended in the event of a problem. Some equipment, such as a functional, working proximity sensors and fall detectors can reinforce the safety of children. However, these types of equipment are not intended to replace close supervision.

! **WARNING** : Pools can represent a serious danger to small children. Drowning happens very quickly. Children in the vicinity of the pool require constant vigilance and active supervision, even if they know how to swim. Designate one person responsible for supervision. The physical presence of a responsible adult is mandatory while the pool is open.



! The safety cover is no substitute for good sense or individual responsibility, or for the vigilance of a responsible adult, which remain key in ensuring the safety of young children. Children must not play with the safety cover, nor should the cleaning of the cover be entrusted to children. In the case of a breakdown or malfunction of the cover, or should the cover be temporarily unavailable, take all steps necessary to prevent young children from accessing the pool.

Be careful not to leave toys in or around an unwatched pool, these could attract children. Teach children to swim as soon as possible! In the event of an accident:

- get the child out of the water as quickly as possible ;
- call the for help immediately and follow the advice given ;
- remove the wet clothes and wrap the child in warm blankets.

! Pool chemicals should be stored out of the reach of children; store them in a safe, inaccessible location. Never leave the cleaning accessories nearby.

15.4 Safety cover

! The cover can only act as a safety cover (and comply with the French safety standard NF P90 308) if end of the slat cover is fastened to pool wall. Therefore, the cover must systematically be attached to the safety fasteners (*Paragraph 12.4.4, page 52*). Safety is only assured if the cover is installed in accordance with the instructions provided in this document and is closed and locked.

Remain vigilant while manipulating the cover. Before running the motor, the person operating the cover must check :

- that there is no-one in the pool and keep watch over the pool while opening or closing the cover ;
- that no floating object or automatic cleaner could hinder movement of the slat cover ;
- that the water level is constant and complies with manufacturer's recommendations (not too high, not too low), so that the slat cover can pass between the beam and the pit wall (*Paragraph 12.5, page 53*) ;
- Watch the cover moving until it reaches its end of travel.

! The cover must be fully opened or completely closed, never leave the cover in an intermediate position. Do not stand, walk or jump on the safety cover.

In the event that the automatic safety cover is inoperative, or a malfunction prevents the cover from being closed and secured, or the equipment or the pool is temporarily unavailable, take all measures necessary to deny young children access to the pool until the cover is repaired or normal operating conditions are resumed.

The cover must only be operated by responsible adults. It may be operated by children aged 8 years and over, by persons with mental, physical or sensory disabilities, and by persons with no experience or knowledge, subject to the condition that:

- said persons are correctly supervised ;
- said persons have been given instructions concerning the safe use of the cover and the pertaining risks and that they have understood said.

16. WATER TREATMENT

16.1 Water filtration

! The pump power supply must be protected by a 30mA RCD upstream from the installation, and therefore connected to the electrical panel provided.

As a safety precaution, the filtration system should be stopped while the pool is in use. The pump should never be allowed to run dry (without water).

16.1.1 Using the filter multi-port valve

! Always stop the pump before changing the position of the multi-port valve, failure to do so could cause serious damage to the filter and will cancel the guarantee.

- **FILTRATION:** water arrives from the pump and filters up through the sand from the top to the bottom and is returned to the pool ;
- **BACKWASH:** The water loosens up the sand by passing through it from the bottom to the top, carrying impurities away to the drain. A backwash should be carried out as soon as the pressure gauge needle enters the red zone ;
- **RINSE:** Water passes through the filter from the top to the bottom before being directed to waste (approx 30 s.), and then switches to FILTRATION (evacuation of dirty water that remains in the pipes) ;
- **CIRCULATION:** water circulates without passing through the filter ;
- **DRAIN:** water passes from the pool to waste (flocculation, etc.) ;
- **CLOSED:** No water is circulating. Never allow the pump to run with the valve in this position. Similarly, make sure that the positions of the various valves will allow circulation of water.

16.1.2 Commissioning the filter

! Before starting the pump, make sure that all the ¼ turn valves are open and the 6-way valve is set to FILTRATION.

! Before using the filter in filtration mode, carry out a backwash to remove any impurities contained in the sand so that they are not carried into the pool. After each back wash, rinse before returning the valve to Filtration mode.

After each backwash, with the valve set to Filtration, the black needle on the pressure gauge indicates the nominal pressure experienced by the filter. This pressure will vary depending on the pump flow rate, the static pressure and the load losses across the pipes. To keep a record of this nominal pressure (calibration) adjust the dial of the pressure gauge so that the blue needle aligns with the black needle.

16.1.3 Cleaning the pre-filter and the filter

After filtration has been running for a certain length of time, the flow rate at the return fitting will diminish. This drop in the flow rate is caused by the gradual clogging of the filter or pre-filter.

If the filter pressure falls below the nominal pressure indicated by the adjustable needle, start by cleaning the pump pre-filter:

- stop the filtration pump and turn the 6-way valve to the CLOSED position ;
- close the return fitting and skimmer suction valves ;
- open the pump pre-filter and remove the basket ;
- use a water jet to remove any impurities, then put the basket back in position ;
- put the pre-filter lid back on, making sure that the seal is in place and that there is enough water to prime the pump ;
- move the 6-way valve to FILTRATION ;
- open the return fitting and skimmer suction valve ;
- switch the pump back on.

If the filter pressure rises above the nominal pressure indicated by the adjustable needle, carry out a backwash of the filter after first leaning out the pre-filter:

- stop the filtration pump and move the 6-way valve to BACKWASH ;
- make sure that a waste pipe (not provided) has been connected to the waste outlet (WASTE) ;
- switch the pump on. Cleaning will begin after a few seconds. Monitor the colour of the water in the turbidity sight glass ;
- as soon as the water runs clear, stop the pump and move the 6-way valve to RINSE ;

- let the pump run for about 30 seconds. The purpose of this is to evacuate and impurities left in the valve and to stabilise the sand ;
- stop the pump and move the 6-way valve to FILTRATION ;
- switch the pump on.

After the backwash, the pressure needle should align with the adjustable needle that indicates the nominal pressure.

16.1.4 Length of the filtration cycle

During the pool season, filtration must run every day for long enough to ensure that the entire pool volume passes three times through the filter within 24 hours. To optimise filtration efficiency, run filtration during the day (between 8 am and 9 pm).

Recommendations will vary depending on the pool water temperature:

- Below 14°C : 5 to 6 hours filtration per day ;
- 15° to 23°C : 6 to 8 hours filtration per day ;
- Above 23°C : 10 to 12 hours filtration per day.

The higher the bather load and the pool water temperature, the longer the filtration time will need to be. To ensure optimal operation of the filtration system and automatic cover maintain a correct water level in the pool.

16.1.5 Setting the filtration timer

- 1-Programming dial
- 2-Switching segments (1=15min)
- 3-Needle for setting the time
- 4-AM/ PM indicator
- 5-Operating mode : ON-AUTO-OFF

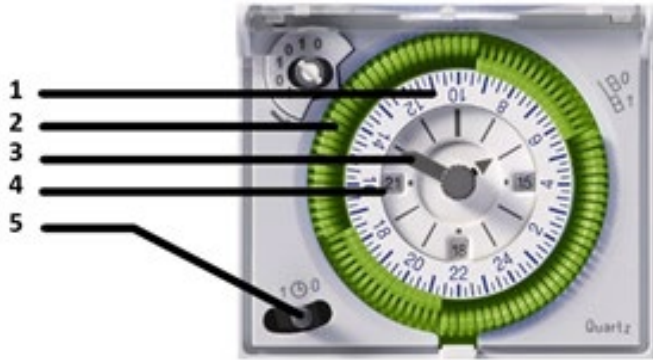
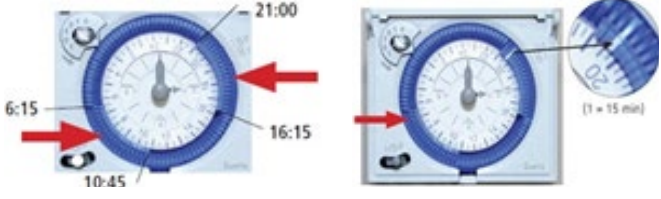
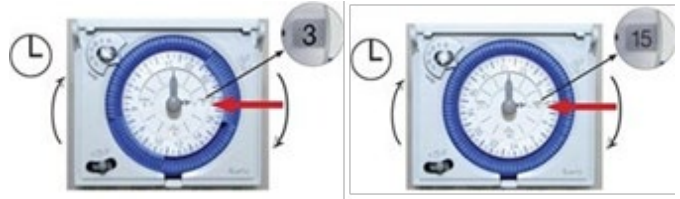

Figure 70 – Setting the filtration timer to the correct time

OPERATING INSTRUCTIONS

Setting the time
 Example : 3:00 & 3:00 PM

Setting the filtration windows
 Example: 6:15M-10:45PM & 4:15AM-9:00PM when ON



Selecting the operating mode
 1 = forced on 0= forced off AUTO = automatic



Figure 71 – Programming the filtration windows

16.2 Maintaining pool water quality

Correct use of your pool requires optimal water treatment. For this, follow the recommendations concerning operation of your filtration group: commissioning, bather load for passing water through the filter, maintenance and monitoring of the system (pipes, nuts and bolts). Monitor clogging of the filter (refer to the filter backwash procedure).

To fill the pool, use drinking water the properties of which are compatible with the liner. Use of well water or water from a private source is prohibited.

The pool water must be tested and treated regularly in order to maintain water quality. The frequency of treatment will vary depending on the pool's situation, in addition, the user should familiarise themselves with the use of the various products that may be needed to treat the pool and maintain water quality. During the winter season, an algacide and/ or winterizing product may be added to the pool (not supplied).

Test the pool water properties regularly to ensure that they remain within the following limits:

- if the pool is treated with Chlorine, pH between 7.0 and 7.4, free Chlorine concentration between 0.7 and 1.2 mg/L ;
- if the pool is treated with Bromine, pH between 7.6 and 8.0, Bromine concentration between 1 and 2mg/l.

The TH (calcium hardness) which measures the calcium hardness of water, that is, the concentration of calcium ions, and the TAC (total alkalinity), that is, the concentration of Hydrogen Carbonate ions, must be between 100 ppm and 250 ppm. A high TAC and/or TH could lead to the deposition of calcium deposits on the liner and on the cover slats, these would be unsightly and could hinder correct articulation of the cover. A lower TAC or TH could make the water aggressive and lead to the corrosion of metallic parts of the pool, such as the stainless steel ladder.

Waste water from the pool should be disposed of in accordance with the regulations in effect in the area in which the pool is installed, these may vary. Furthermore, the user should use only disinfection systems and products compatible with the components constituting the PVC automatic cover, and must comply with the recommendations for use issued by the manufacturers of said systems and products.

17. MAINTENANCE OF YOUR URBAN POOL

At least twice year (at the beginning and end of the pool season), carry out a careful inspection of those parts of the pool that are essential to safety. Replace any element presenting wear likely to prevent correct installation of the cover. Use original spare parts, or parts that comply with the specifications set out in this document.

At least once a year, check that the electrical contacts of the power cable and the various electrical equipment connection cables are correctly tightened.

17.1 Maintenance of the pool structure

Wood is a living material; changes in humidity and temperature will cause the wood to work and could lead to cracking or splitting. This is a natural phenomenon that in no way impacts the service life of our products.

The autoclave treatment undergone by the wooden elements of this pool complies with the standards in effect and presents absolutely no danger to people or animals coming into contact with it. Under no circumstances should any product (for example: wood stain, paint, oil, micro porous product, etc.)

Inevitably, the wood will become dirty over time. You may clean the wood once a year using a high pressure jet to remove dirt from the pores in the wood. Adjust the water pressure carefully to avoid damaging the surface treatment, or raising wood fibres. Inspect the wooden structure regularly (particularly the coping and wooden access steps) and remove any splinters that may have appeared.

After any weather event (heatwave, strong wind, heavy rain, etc.), inspect the pool structure carefully. If any gaps have appeared between the slats, fit them back together as quickly as possible.

This pool features free-standing walls. However, a slight deformation of the walls between the supporting braces may be observed, caused by the natural elasticity of wood. The pool is delivered as a kit and is not designed to be dismantled. Check accessible nuts and bolts over the whole structure regularly and carry out any necessary maintenance (tighten, treat rust, etc.).

The liner of the pool should not be subject to aggressions that could impair its leaktghtness.

Over the course of its service life, it may be necessary to completely empty the pool. During this operation, take all the measures necessary to avoid dangers (falls, slips, etc.). Avoid prolonging this period beyond 48 hours, in the case of in-ground or partially in-ground installations, pressure exerted by the ground may cause deformation of the structure.

Failure to respect maintenance instructions may entail serious risks to health, especially that of children.

17.2 Maintenance of the filtration pump

To clean the pump, switch it off by moving the button on the timer to 0, then disconnect the pump at the transformer. Close the pump's suction and return valves. Unscrew the lid to access the basket. Clear out any debris from the basket, then replace and tighten the lid.

17.3 Maintenance of the cover

The cover must be cleaned regularly. Organic or vegetable matter left to stagnate on the cover over a prolonged period of time can cause staining of the slat cover that may be permanent.

A deep clean of the cover, at least twice a year, upon opening the pool and winterizing the pool, is recommended. To deep clean the cover, use a high pressure jet of hot water and a descaling product. The cover should only be cleaned using suitable, recommended products. These products should not be abrasive or contain PVC solvents. Failure to respect these instructions will entail the rejection of any resulting guarantee claim.

17.4 Winterizing the pool

The pool must not be left empty over the winter period (or for any prolonged period of time). In fact, the liquid mass plays a dual role, it provides thermal insulation and acts as ballast, holding the liner in place against the pool structure.

Close the valves, remove the filtration pump and part of the pipework by undoing the locking nuts on the valves (downstream for the top valve and upstream from the bottom valve). Store the components removed. In areas susceptible to freezing, screw a winterizing plug (gizmo) into the bottom of the skimmer to absorb the expansion of ice and protect the skimmer. Remove any water treatment products from the skimmer (Chlorine tablets, flocculant, etc.).

Keep the cover closed while the pool is winterized (rolled out over the pool).

TIP: winterizing is not mandatory, especially if the weather is mild with temperatures that remain above 0°C. In this case; maintain the water level in the pool and run filtration 2 to 3 hours per day. Check the water level in the pool regularly. In the case of significant freezing, run the filtration pump at least 30 minutes every two hours.

18. GUARANTEE CONDITIONS

Keep the installation and operation instructions, the invoice, proof of purchase and the tracking number that can be found on the packages. The guarantee does not cover:

- natural ageing of the materials (appearance of corrosion, natural deformation of the wood, etc.);
- damage caused by improper handling while assembling or using the accessories (impacts, scratches, etc. that could alter the surface treatments);
- incidents not directly related to the normal use of the pool or its accessories.

The guarantees set out hereinafter cover parts recognised as defective by our services and are limited to the replacement of the part(s) in question. The cost of dismantling and reassembly is not covered.



IMPORTANT: The lengths of the guarantee periods listed in this paragraph start on the date of purchase.

18.1 Guarantee covering the wooden components

Wooden components are covered by a 10 year guarantee from the manufacturer against insect infestation and rotting (wood is high pressure autoclaved in accordance with the standards in effect).

This guarantee does not cover natural warping of the wood (appearance of cracks, splitting that is no way impacts the mechanical strength of the wood) or colour changes caused by weathering. Similarly excluded are defects caused by improper assembly and/ or storage: warped slats (exposure to sunlight, assembly delayed after undoing the package), as well as slats that were warped or broken due to assembly other than as described in the installation instructions. Furthermore, any wooden component to which a product (wood stain, etc) has been applied will not be covered by this guarantee.

Due to the constant pressure exerted by the water, the pool walls may bulge slightly over time. This phenomenon, attributable to the natural elasticity of wood, will stabilise of its own accord and will not entail any risk of failure of the wooden slats.

Furthermore, any wooden components to which a product has been applied will not be covered by any guarantee.

Make sure that no additional structures (pool shelter, terrace, etc.) are resting on the pool walls or coping. The pool walls and coping are not sized to bear mechanical loads in addition to that exerted by the swimming pool water. The presence of equipment bearing on the pool walls or coping will automatically cancel the guarantee cover the pool walls and coping.

18.2 Guarantee covering accessories

Accessories are guaranteed against manufacturing and/or assembly defects that may interfere with correct operation of the pool, within the scope of the guarantee conditions. Notably, the guarantee conditions stipulate that the user must carry out periodic checks and maintenance necessary for the pool to operate correctly. The successful outcome of any claim will be contingent on strict adherence to the guarantee conditions.

18.2.1 Liner guarantees

SUBJECT AND SCOPE OF THE GUARANTEE	TERM OF THE GUARANTEE	CONDITIONS COVERING ACCEPTANCE OF A CLAIM
Leaktightness and durability of the weld seams. The guarantee is limited to replacement or repair of the liner recognised as defective without any other damages or interest.	10 years against leaks	Adherence to conditions governing fitting, use and maintenance

Folds that appear after the liner is fitted are not covered in the scope of this guarantee, these could be the result of pool water chemical and physical properties that are outside the acceptable ranges (the water

temperature must be below 28°C, the pH must be between 7.0 and 7.4 if the pool is treated with water, or between 7.4 and 8.0 if the pool is treated with Bromine, and the concentration of disinfectant must be within the range recommended by the manufacturer of the water treatment products).

Also excluded from the scope of the guarantee is the appearance of yellow stains or discolouration along the water line. This may be the result of the deposition of organic compounds floating on the surface of the water (sun creams and oils, residue of hydrocarbon combustion or smoke from wood fires). The water line should be cleaned regularly using a suitable product (not provided) and non-abrasive sponge. Water with a very high concentration of calcium can also cause this type of staining due to the build-up of limescale on the membrane. Hard water with a TH greater than 250 ppm should be treated with a product to eliminate

Calcium and suitable for use in pools (not provided). Your water supplier can provide information regarding the hardness of your water;

The following are also excluded from the scope of this guarantee:

- stains caused by the growth of algae and micro-organisms: the pool water should be treated regularly with an appropriate dose of a suitable disinfectant and algicide ;
- stains, discolouration and wrinkles caused by direct contact with solid oxidising products in direct contact with the membrane (thrown directly into the pool) or pockets of excessively high concentrations of oxidising agents (Frequently associated with failure to run filtration during the dissolution phase) ;
- stains caused by stagnation and/or decomposition of a foreign body in contact with the liner (dead leaves, oxidisable metallic objects, miscellaneous detritus, etc.) ;
- damage caused by direct contact with incompatible materials such as bitumen, tar, oils, polystyrene panels, polyurethane. Never apply adhesive tape or glue to the membrane ;
- tears in the liner under the hung liner locking track caused by moving the liner without first releasing it from the locking track.

18.2.2 Guarantee covering the sand filtration pump

SUBJECT AND SCOPE OF THE GUARANTEE	TERM OF THE GUARANTEE
Operation of the motor	2 years
Leaktightness of the filter tank	5 years
Leaktightness of tank unions, the filter drain, the multi-port valve	2 years
Leaktightness of semi-rigid pipes	2 years

18.2.3 Guarantee covering ABS fittings (skimmer, return fitting)

SUBJECT AND SCOPE OF THE GUARANTEE	TERM OF THE GUARANTEE	CONDITIONS COVERING ACCEPTANCE OF A CLAIM
Leaktightness and durability of ABS parts	10 years	Adherence to installation, operating and maintenance conditions

18.3 Guarantee covering the automatic cover

18.3.1 Guarantee covering the automatic cover mechanical assembly

SUBJECT AND SCOPE OF THE GUARANTEE	TERM OF THE GUARANTEE	CONDITIONS RESULTING IN REJECTION OF A CLAIM
<p>AXLE Notably performance over time and corrosion</p>	5 years	<p>Failure to adhere to recommendations provided in this document concerning the pH of the pool water and the concentration of disinfectants.</p> <p>The use of a salt water electrolyser in the absence of a functional earth.</p> <p>Damage to the anodised coating of the axle and corrosion that could result from rubbing against abrasive elements (stone, etc.) while it is moving.</p>
<p>BEAM Performance over time</p>	5 years	<p>Use of the beam as a diving platform.</p> <p>Placing any kind of load weighing more than 80 kg/m² on the duckboarding/ beam assembly.</p> <p>Damage to the beam's lacquer coating and corrosion resulting from friction against abrasive elements (stone, flag stones, etc.).</p>
<p>MOTOR Splash-proof and correct operation over time</p>	2 years	<p>Installation that does not comply with the instructions set out in this document and those concerning options in the case of an in-ground or partially in-ground configuration. If the pool is installed in-ground or partially in-ground, immersion of the motor following a rise in the water level (storm, etc.) in the motor pit due to the absence of a peripheral drain under the pool (or inefficient drainage) or a sump pump on the floor of the pit.</p> <p>Damage caused by lightning or overvoltages.</p>
<p>ELECTRICAL PANEL correct operation of the electrical panel</p>	2 years	<p>Failure to respect installation and connection recommendations (power supply and connection of the pool's electrical equipment).</p> <p>Damage caused by lightning or overvoltages.</p> <p>Damage caused by water entering the pit because it is installed in an area exposed to rain.</p>

18.3.2 Guarantee covering the PVC slats of the cover apron

Behaviour over time	5 years	CONDITIONS RESULTING IN REJECTION OF A CLAIM
Slat leaktightness, loss of leaktightness impacting at least 2% of the slats constituting the slat apron.	5 years	Loss of leaktightness caused by the over pressure of air trapped in slats that rested on the pit wall out of contact with water due to a drop in the water level, or slats that were held above the water by a floating object (float, toy, thermometer, floating dispenser, etc.) underneath the cover.
Slat articulations	5 years	<p>Articulation defects caused by:</p> <ul style="list-style-type: none"> the build up of dirt on the slat articulations (moss, detritus, limescale, etc.) due to inadequate cleaning or poorly maintained water; deformation of the articulations caused by abnormal stress loading on the slat apron, such as the accumulation of snow, forgetting to release the safety fasteners on the roller, etc.; deformation of the articulations caused by manipulating the cover while the water level does not comply with recommendations in this document, leading to impacts and friction against the beam or the top of the pit wall; an object (float, toy, thermometer, floating dispenser, etc.) trapped in the cover turns while it is being rolled up; deformation of the articulations caused by incorrect setting, or failure to set ,the ends of travel.
Performance over time	5 years	Swelling or deformation of the slats, caused by their exposure to the sun before being installed in the pool water.
Material	5 years	<p>Damage attributable to hail storms.</p> <p>Damage caused by manipulating the cover apron while the water level does not comply with recommendations in this document, leading to impacts and friction against the beam or the top of the pit wall.</p> <p>Swelling of the slats caused by a floating object (float, toy, thermometer, floating dispenser, etc.) trapped under the cover, or a water level that is too low, preventing the cover from remaining in contact with the cover.</p>
Sudden or abnormal discolouration of the slats or the appearance of permanent stains on the surface of the slats covering at least 10% of the effected slats.	5 years	<p>Slow, gradual discolouration of the slats caused by UV radiation and/or disinfectant products.</p> <p>Stains caused by the use of richly pigmented tanning sun creams (brown), by fallout from combustion motor exhaust gases, fallout from fuel boilers and chimneys, or by tannins leaching from decomposing leaves.</p> <p>(Dis)coloration caused by prolonged contact between the slats and winter cover or tarp installed over the cover.</p> <p>Stains attributable to improper maintenance.</p> <p>Stains due to the formation of metal sulphides resulting from the reaction of Hydrogen Sulphide released by micro-organisms growing on the surface of the slats (bacteria, fungii, etc.) with metal ions in the pool water.</p>

NOTA BENE: in case of the partial replacement of cover apron slats (inside or outside the scope of the guarantee), the shade of the new slats will differ slightly from the colour of the rest of the cover apron because they have not yet been exposed to the sun (the older the cover, the more pronounced the difference could be). The colour difference will fade over time.

19. ENVIRONMENTAL PROTECTION AND DISPOSAL

Consumers are legally obligated to properly dispose of electronic devices, lamps, and batteries at the end of their lifespan.

They can be returned free of charge at designated public collection points or through retailers.

Light bulbs and batteries that can be safely removed and are not permanently installed must be separated for separate disposal.

The details of legally compliant disposal are governed by regional legislation.

The symbol of a crossed-out waste bin indicates that electronic devices and batteries must never be disposed of in household waste after their lifespan.

Symbols placed below the waste bin indicate the possible presence of certain substances (lead = Pb, mercury = Hg, cadmium = Cd).

This separation is necessary because batteries and electronic devices contain both valuable resources and substances that are harmful to humans and the environment.

By recycling, collecting, and reusing batteries and suitable electronic devices, you contribute to the preservation and protection of the environment and human health.

Notes

A series of horizontal dotted lines for writing notes.

Notes

A series of horizontal dotted lines for writing notes.



ATTESTATION DE CERTIFICATION

CERTIFICATE OF

CHAINE DE CONTRÔLE PEFC CHAIN OF CUSTODY PEFC CERTIFICATION

Société / Company : **PROCOPI**
35137 PLEUMELEUC

N° Chaîne de contrôle : **FCBA/12-01382**
Chain of Custody N°

Produits Products Categories	Domaine d'application Scope	Méthode utilisée Method	Origine des matières premières Raw materials origin
09010 - Constructions et leurs éléments Buildings and their parts	Fabricant d'aménagements extérieur en bois Wooden outdoor accomodations manufacturing	Transfert en pourcentage moyen Average percentage method	Certifiée Certified

La chaîne de contrôle de l'entreprise ci-dessus désignée est en conformité avec les exigences PEFC* en vigueur.

The chain of custody of the company appointed above is in compliance with the requirements PEFC in force.

Ce certificat est délivré selon le règlement de gestion de chaîne de contrôle PEFC de FCBA en vigueur.

This certificate is delivered according to the FCBA requirements for the PEFC chain of custody

* standards PEFC/FR ST 2002 : 2013 et PEFC/FR ST 2001 :2008 du schéma français de certification forestière 2017-2022, traduction des standards PEFC ST 2002 : 2013 et PEFC ST 2001 :2008 du document technique de PEFC C

Ce certificat atteste la vérification de la chaîne de contrôle PEFC, fondée sur un contrôle permanent. Il ne peut préjuger d'évolutions ou de décisions qui seraient prises en cours d'année. La liste des entreprises sous certification est disponible sur les sites Internet : www.fcba.fr et www.pefc.org.

This document testifies the certification of PEFC chain of custody, based on a permanent assessment. There can not be any evolution or decision which would be taken in the course of the year after examination of the results of the audits of follow-up. This document is the property of FCBA. In case of the mark's withdrawal, the original and all the copies must have returned to FCBA.



Siège Social
10, rue Galilée
CS 81050 Champs sur Marne
77447 Marne la Vallée Cedex 2
www.fcba.fr

Numéro de Certificat : **00010258**

Certificate Nr :

Annule et remplace N°

Cancel and replace :

Date d'émission : 02/02/2022

Issued :

Valable jusqu'au : 01/02/2027

Valid until :

Nombre de pages /

1

Pages :

LE DÉCIDEUR
TECHNIQUE

Jérôme MONTEFERRARIO

LE DIRECTEUR
CERTIFICATION

Alain HOCQUET

